

Sr. No.

ENTRANCE TEST-2023

SCHOOL OF BIOLOGICAL SCIENCES

NANOTECHNOLOGY

Total Questions : 60

Time Allowed : 70 Minutes

Question Booklet Series

A

Roll No. :

--	--	--	--	--	--

Instructions for Candidates :

1. Write your Entrance Test Roll Number in the space provided at the top of this page of Question Booklet and fill up the necessary information in the spaces provided on the OMR Answer Sheet.
2. OMR Answer Sheet has an Original Copy and a Candidate's Copy glued beneath it at the top. While making entries in the Original Copy, candidate should ensure that the two copies are aligned properly so that the entries made in the Original Copy against each item are exactly copied in the Candidate's Copy.
3. All entries in the OMR Answer Sheet, including answers to questions, are to be recorded in the Original Copy only.
4. Choose the correct / most appropriate response for each question among the options A, B, C and D and darken the circle of the appropriate response completely. The incomplete darkened circle is not correctly read by the OMR Scanner and no complaint to this effect shall be entertained.
5. Use only blue/black ball point pen to darken the circle of correct/most appropriate response. In no case gel/ink pen or pencil should be used.
6. Do not darken more than one circle of options for any question. A question with more than one darkened response shall be considered wrong.
7. There will be '**Negative Marking**' for wrong answers. Each wrong answer will lead to the deduction of 0.25 marks from the total score of the candidate.
8. Only those candidates who would obtain positive score in Entrance Test Examination shall be eligible for admission.
9. Do not make any stray mark on the OMR sheet.
10. Calculators and mobiles shall not be permitted inside the examination hall.
11. Rough work, if any, should be done on the blank sheets provided with the question booklet.
12. OMR Answer Sheet must be handled carefully and it should not be folded or mutilated in which case it will not be evaluated.
13. Ensure that your OMR Answer Sheet has been signed by the Invigilator and the candidate himself/herself.
14. At the end of the examination, hand over the OMR Answer Sheet to the invigilator who will first tear off the original OMR sheet in presence of the Candidate and hand over the Candidate's Copy to the candidate.



(Chemistry)

- The coordination number of constituent ions in calcium fluoride is :
 - 1 : 1
 - 8 : 4
 - 4 : 8
 - 1 : 8
- The % ionic character of H–F bond (with electronegativity of F = 3.98 and H = 2.0) is :
 - 17.95
 - 38.61
 - 45.40
 - 69.65
- According to Fajan's rules, covalency is favoured by :
 - Small anion and large cation
 - Small anion and small cation
 - Large anion and a small cation
 - Large anion and a large cation
- The bond order for O_2^{2-} :
 - 1
 - 2
 - 1.5
 - 2.5
- According to kinetic theory of gases, the average translational kinetic energy per molecule of an ideal gas at 300 K is :
 - $1.242 \times 10^{-20}J$
 - $6.21 \times 10^{-21}J$
 - $4.14 \times 10^{-21}J$
 - $2.07 \times 10^{-21}J$
- The compressibility factor for a perfect gas is equal to :
 - Zero
 - 1
 - Zero to 1
 - Depends upon the nature of gas
- Select the most appropriate statement :
 - Numerically Surface tension is equal to surface energy but with units different than that of surface energy
 - The spherical shape of liquid drops and gas bubbles is because of the viscosity of liquids
 - The surface tension of fluids decreases linearly with an increase in temperature
 - The surface tension of fluids vanishes roughly 6 degrees below the critical temperature
- For the crystal plane that cuts the crystal axes at (2a, 3b, c), the Miller indices are given as :
 - (2 3 6)
 - (3 2 6)
 - (6 2 3)
 - (6 3 2)
- In the presence of water, alkali metal hydrides release :
 - Hydrogen and Metal
 - Hydrogen and Metal hydroxide
 - Oxygen and Metal
 - Oxygen and Metal Hydroxide
- Which among the following groups of ions do not show the properties characteristic of transition elements ?
 - Cu, Ag, Au
 - Ni, Pd, Pt
 - Mn, Cu, Ni
 - Zn, Cd, Hg

11. The shielding effect of electrons in lanthanides decreases in the order :
- (A) $s > d > p > f$
 (B) $s > p > d > f$
 (C) $f > d > p > s$
 (D) $f > s > d > p$
12. In the complex $K_4[Fe(CN)_6]$, Fe has an oxidation state and an effective atomic number of :
- (A) 2+ and 52
 (B) 2+ and 36
 (C) 3+ and 52
 (D) 3+ and 36
13. Which among the following is true for Cyclopentadienyl cation ?
- (A) It is a cyclic, conjugated aromatic cation
 (B) It is an acyclic conjugated cation that obeys the Huckels rule
 (C) It is not a conjugated cation
 (D) It is a cyclic conjugated anti-aromatic molecule
14. The absolute configuration of the two chiral centers in Mesotartaric acid is :
- (A) 2R, 3R
 (B) 2R, 3S
 (C) 2S, 3S
 (D) 2S, 3R
15. The most stable conformation of cyclohexane is :
- (A) Chair
 (B) Twist Boat
 (C) Half Chair
 (D) Boat
16. Select the most stable carbanion :
- (A) $CH_3CH_2^-$
 (B) $(CH_3)_2CH^-$
 (C) $(CH_3)_3C^-$
 (D) $C_6H_5CH_2^-$
17. The substituent Nitro in nitrobenzene is :
- (A) An electron donating group that favours electrophilic substitution at Ortho and Para positions
 (B) An electron withdrawing group that favours electrophilic substitution reactions at meta position
 (C) An electron donating group that facilitates its nucleophilic substitution reactions at meta position
 (D) An electron withdrawing group that favours its electrophilic substitution reactions at ortho, para and meta positions
18. SN^1 reaction of alkyl halides is independent of :
- (A) Concentration of the attacking nucleophile
 (B) Concentration of alkyl halide
 (C) Nature of the leaving group
 (D) Nature of solvent
19. The chemical transformation
- $$C_6H_5CHO \xrightarrow[EtOH, H_2O]{CN^-, \Delta} C_6H_5 - COCHOHC_6H_5$$
- is better known as :
- (A) Benzillic acid Rearrangement
 (B) Claisen Rearrangement
 (C) Benzoin Condensation
 (D) Huben-Hoesch Reaction

20. Conversion of cyclohexanone to a cyclic ester using peracid is :
- (A) Oppenauer oxidation
 (B) Gatterman reaction
 (C) Schmidt reaction
 (D) Baeyer-Villiger Oxidation
21. In a certain process, a system absorbed 250 Joules of heat while doing 300 Joules of work. The net change in the internal energy of the system will be :
- (A) -550 Joules
 (B) -50 Joules
 (C) +50 Joules
 (D) +550 Joules
22. Expansion of a gas under adiabatic conditions results in :
- (A) Decrease in temperature if the gas is ideal
 (B) Increase in temperature if the gas is ideal
 (C) Decrease in temperature if the gas is non-ideal
 (D) Decrease in temperature whether the gas is ideal or non-ideal
23. The change in entropy when two moles of an ideal gas expand reversibly from a volume of 5 dm³ to 50 dm³ at a temperature of 300 K is :
- (A) 11.488 kJK⁻¹
 (B) 11.488 JK⁻¹
 (C) 38.29 kJK⁻¹
 (D) 38.29 JK⁻¹
24. Select the incorrect statement :
- (A) The Clapeyron-Clausius equation is valid for one-component two-phase systems
 (B) The degrees of freedom for a one-component system can change from Zero to two
 (C) The eutectic point in the phase diagram for the Lead-Silver system has zero degrees of freedom
 (D) In simple two component Eutectic systems, composition corresponding to eutectic point has the highest melting point
25. In electrolyte solutions :
- (A) Increase in dilution decreases the mobility of constituent ions
 (B) The fraction of current carried by any ion depends upon the mobility of all the constituent ions
 (C) Increase in dilution increases the specific conductance but decreases molar conductance
 (D) Increase in dilution increases the specific conductance as well as the molar conductance
26. In the conductometric titration of a strong acid with a weak base :
- (A) The conductance decreases up to the end point and then increases
 (B) The conductance increases up to the end point and then remains constant
 (C) The conductance decreases up to the end point and then remains constant
 (D) The conductance shows no change up to the end point and then increases

27. For an electrochemically reversible Galvanic Cell :
- The electrical energy is greater than the enthalpy of the cell reaction if the temperature coefficient of the EMF of the cell is positive
 - The electrical energy is less than the enthalpy of the cell reaction if the temperature coefficient of the EMF of cell is positive
 - The electrical energy is always less than the enthalpy of the cell reaction
 - The electrical energy is always more than the enthalpy of the cell reaction
28. Select the incorrect statement :
- For a zero-order reaction, the average rate is always equal to the instantaneous rate
 - The $t_{1/2}$ of a zero-order reaction doubles if the concentration of reactant is doubled
 - The $t_{1/2}$ of a first-order reaction is independent of the initial concentration of the reactant
 - The quantum yield of the photochemical decomposition of HI does not change with the progress of the reaction
29. The correct conversion factor for the coefficient of viscosity (η) is :
- $\eta(\text{in CGS units}) = 0.1 \times \eta(\text{in SI units})$
 - $\eta(\text{in CGS units}) = 10 \times \eta(\text{in SI units})$
 - $\eta(\text{in CGS units}) = 0.01 \times \eta(\text{in SI units})$
 - $\eta(\text{in CGS units}) = 100 \times \eta(\text{in SI units})$
30. Select the incorrect statement :
- Heat change at constant volume is equal to change in internal energy
 - The enthalpy change associated with a reaction is independent of the path of the reaction
 - Specific heat is an intensive property
 - The standard enthalpy of neutralization of strong acids depends on the concentrations of acid and base
31. Tollen's reagent is :
- Ammonical solution of silver nitrate
 - Aqueous solution of silver nitrate
 - Acidic solution of silver nitrate
 - Alcoholic solution of silver nitrate
32. The metal commonly used for the detection of N, S and halogens in organic compounds is :
- K
 - Li
 - Na
 - Mg

(Physics)

33. A bullet is fired from a gun, the recoiling of gun is an example of :
- (A) Conservation of energy
 - (B) Conservation of momentum
 - (C) Conservation of angular momentum
 - (D) Both (A) and (B)
34. The special theory of relativity states that all physical laws are the same :
- (A) In frames of reference which accelerate
 - (B) In frames of reference which move in circles
 - (C) In frames of reference which move at uniform velocity
 - (D) In frames of reference which move in ellipses
35. Two photons approach each other, what is their relative velocity ?
- (A) c
 - (B) $2c$
 - (C) 0
 - (D) c^2
36. The differential equation of the simple harmonic motion given by $x = A \cos(\omega t + \alpha)$ is :
- (A) $\frac{d^2x}{dt^2} + \omega^2x = 0$
 - (B) $\frac{d^2x}{dt^2} - \omega^2x = 0$
 - (C) $\frac{d^2x}{dt^2} + \omega x = 0$
 - (D) $\frac{d^2x}{dt^2} - \omega x = 0$
37. Gauss law will be invalid if :
- (A) Electric charge was not quantized
 - (B) The inverse square law isn't exactly true
 - (C) The velocity of light isn't a universal constant
 - (D) None of these
38. The Biot-Savart law states that :
- (A) The magnitude of the magnetic field is inversely proportional to the square of the distance from the current element
 - (B) The magnitude of the magnetic field is directly proportional to the current through the current element
 - (C) The magnitude of the magnetic field is directly proportional to the length of the current element
 - (D) All of the above
39. Lenz's law is the consequence of :
- (A) Law of conservation of Mass
 - (B) Law of conservation of Energy
 - (C) Law of conservation of Momentum
 - (D) All of the above
40. For time varying currents, the field or waves will be :
- (A) Electrostatic
 - (B) Magneto static
 - (C) Electromagnetic
 - (D) All
41. Entropy occurs due to :
- (A) Temperature change
 - (B) Mass change
 - (C) Change in macroscopic variables
 - (D) None

42. As the wavelength of the radiation decreases, the intensity of the black body radiations :
- Remains constant
 - Decreases
 - First increases then decrease
 - Increases
43. At temperature T , the power radiated by a body is Q watts. At the temperature $3T$ the power radiated by it will be :
- $3Q$
 - $81Q$
 - $27Q$
 - $9Q$
44. According to the law of equipartition of energy, the energy associated with each degree of freedom is :
- $E = k_B T$
 - $E = 1/2 k_B T$
 - $E = 3/2 k_B T^2$
 - $E = 3/2 k_B T$
45. Lissajous figure :
- is a curve formed by the superposition of two simple harmonic motions
 - is a curve traced out by a point that undergoes two simple harmonic motions in mutually perpendicular directions
 - is a curve traced out by a point that undergoes two simple harmonic motions
 - All of the above
46. In the Young's double slit experiment both the slits are similar. If the length of one of the slits is halved, which of the following is true ?
- Dark fringes become brighter
 - Bright fringes become wider
 - Dark fringes become darker
 - Bright fringes become darker
47. Sound with a frequency of less than 20 Hz is called :
- Ultrasonic
 - Infrasonic
 - Supersonic
 - Sonic
48. Decibel is a unit of :
- Solar Intensity
 - Sound Intensity
 - Velocity of Sound
 - None
49. The minimum energy required for a photoelectron to escape from a metal surface :
- Work function
 - Planck's constant
 - Atomic energy
 - Binding energy
50. The uncertainty principle and the concept of wave nature of matter was proposed by _____ and _____ respectively.
- Heisenberg, Planck
 - Heisenberg, de-Broglie
 - de-Broglie, Heisenberg
 - Planck, Heisenberg
51. Orbital is :
- Circular path around the nucleus in which the electron revolves
 - Space around the nucleus where the probability of finding the electron is maximum
 - Amplitude of electrons wave
 - None of these
52. Uncertainty principle gave the concept of :
- Probability
 - An orbital
 - Wavelength
 - None of these

53. Schroder equation governs wave form of :
- (A) Classic Mechanics
 - (B) Quantum mechanics
 - (C) Both (A) and (B)
 - (D) None
54. Which of the following is the time independent Schrodinger equation ?
- (A) $H\psi = E\psi$
 - (B) $H\psi = -E\psi$
 - (C) $H\psi = 1/E\psi$
 - (D) $1/H\psi = E\psi$
55. Zeeman Effect cannot be proved by :
- (A) Bohr's Model
 - (B) Hamiltonian Operators
 - (C) L-S Coupling
 - (D) Quantum-Mechanics
56. Alpha Particle consists of :
- (A) 4 protons
 - (B) 4 neutrons
 - (C) 2 electrons, 2 protons, 2 neutrons
 - (D) 2 protons and 2 neutrons only
57. The specific heat at constant volume of solid obeys Debye's law at :
- (A) High temperatures
 - (B) Low pressure
 - (C) Low temperatures
 - (D) High pressure
58. Many of the semiconductors are crystals of the type :
- (A) Face-centered cubic
 - (B) Body-centered cubic
 - (C) Simple cubic
 - (D) All of the above
59. With an increase in temperature the electrical conductivity of an intrinsic semiconductor :
- (A) Remains same
 - (B) Decreases
 - (C) Increases
 - (D) First increases then decrease
60. MOSFET is :
- (A) Uncontrolled device
 - (B) Temperature controlled device
 - (C) Current controlled device
 - (D) Voltage controlled device

OR
(Biology)

33. Which of the following organic compounds are classified as lipids ?
- Polysaccharides
 - Triglycerides
 - Steroids
 - Prostaglandins
- (A) i, ii and iii
(B) i, ii and iv
(C) ii, iii and iv
(D) i, iii and iv
34. Some enzymes when secreted are in inactive state, such enzymes are called :
- (A) Apoenzymes
(B) Proenzymes
(C) Cofactors
(D) Coenzymes
35. Vitamin K is necessary for blood clotting as it helps in the formation of :
- (A) Fibrinogen in liver
(B) Thromboplastin
(C) Heparin in liver
(D) Prothrombin in liver
36. The building blocks of nucleic acids and proteins are respectively called as :
- (A) Nucleotides and amino acids
(B) Nucleosides and histones
(C) Nitrogenous base and sugar
(D) Sugar and amino acids
37. The lipid layers in plasma membrane remain linked to each other by their :
- (A) Polar ends which are hydrophobic
(B) Non-polar ends which are hydrophilic
(C) Polar ends which are hydrophilic
(D) Non-polar ends which are hydrophobic
38. In eukaryotes, the extra nuclear DNA is present in :
- (A) Mitochondria and chloroplast
(B) Nucleus and Mitochondria
(C) Mitochondria and Golgi bodies
(D) None of the above
39. At what stage of cell division does nuclear membrane disappear ?
- (A) Metaphase
(B) Anaphase
(C) Prophase
(D) Anaphase
40. Which among the following statements is not true ?
- (A) Rough ER synthesizes glycoproteins
(B) Smooth ER synthesizes fatty acids
(C) Smooth ER does not synthesize proteins
(D) Smooth ER synthesizes proteins
41. The process of DNA transcription in prokaryotic organisms occurs in :
- (A) Cytoplasm
(B) Nucleus
(C) Nucleolus
(D) None of the above
42. The scientists who jointly shared the Nobel Prize in Physiology or Medicine 1968 for their interpretation of the genetic code and its role in protein synthesis :
- (A) Nirenberg, Khorana and Holley
(B) Watson, Crick and Wilkins
(C) Nirenberg, Crick and Wilkins
(D) Nirenberg, Watson and Khorana

43. The enzymes that catalyzes the synthesize of RNA from a DNA template are :
- (A) RNA polymerases
 - (B) DNA polymerases
 - (C) Polymerase alpha
 - (D) Polymerase epsilon
44. Which among the following is not a genetic disorder ?
- (A) Down syndrome
 - (B) Neurocysticercosis
 - (C) Cystic fibrosis
 - (D) Sickle cell anemia
45. Most commonly enzymes used in genetic engineering are :
- (A) Ligase and RNA polymerase
 - (B) DNA and RNA polymerase
 - (C) Restriction endonuclease and ligase
 - (D) None of the above
46. Who invented Polymerase Chain Reaction (PCR) technique and was awarded Nobel Prize in Chemistry for 1993 ?
- (A) Watson and Crick
 - (B) Nirenberg
 - (C) Kary Mullis
 - (D) H. Khorana
47. The first genetically engineered hormone produced through recombinant DNA (rDNA) technology by Genentech and Licensed by Elli Lilly and company was :
- (A) Insulin
 - (B) FSH
 - (C) GH
 - (D) Erythropoietin
48. The plasmid that was used for the first time as cloning vector by Herbert Boyer and Stanley Norman Cohen :
- (A) pBR322
 - (B) pSC101
 - (C) pUC18
 - (D) Ti
49. By using a pinhole to only allow images from a particular depth of field, which microscopy enables the visualization of tissues at different focal planes ?
- (A) Phase contrast microscopy
 - (B) Confocal microscopy
 - (C) Electron microscopy
 - (D) All of the above
50. Which of the following biomolecules are mainly detected and analyzed by blotting techniques ?
- (A) Nucleic acids and proteins
 - (B) Carbohydrates and lipids
 - (C) Proteins and lipids
 - (D) None of the above
51. Western blotting identifies and provides preliminary quantitation of a specific _____ based on molecular weight, by SDS-PAGE.
- (A) Protein in a mixture of proteins
 - (B) DNA in a mixture of Nucleic acids
 - (C) RNA in a mixture of Nucleic acids
 - (D) Lipids in a mixture of fatty acids
52. Which among the following can be diagnosed by using ELISA test ?
- (A) HIV
 - (B) SARS-CoV-2
 - (C) Pregnancy
 - (D) All of the above

53. Beta-oxidation of fatty acids occurs only in :
- (A) Cytoplasm
 - (B) Mitochondria
 - (C) Nucleus
 - (D) Nucleolus
54. Which among the following is not inherited metabolic disease ?
- (A) Phenylketonuria (PKU)
 - (B) Maple syrup urine disease (MSUD)
 - (C) Homocystinuria (HCU)
 - (D) Paroxysmal nocturnal hemoglobinuria (PNH)
55. Besides mitochondria, the other production site of ATP is :
- (A) Golgi complex of animals
 - (B) Golgi complex of plants
 - (C) Chloroplast of plants
 - (D) All of the above
56. The normal concentration of amino acids in the blood is between :
- (A) 35 and 65 mg/dl
 - (B) 10 and 25 mg/dl
 - (C) 40 and 80 mg/dl
 - (D) 20 and 55 mg/dl
57. The antibody molecules that can activate the complement are :
- (A) IgG & IgA
 - (B) IgG & IgE
 - (C) IgG & IgM
 - (D) IgM & IgE
58. Hemolytic disease of newborn is an example of _____ reaction.
- (A) Type-I hypersensitivity
 - (B) Type-II hypersensitivity
 - (C) Type-III hypersensitivity
 - (D) Type-IV hypersensitivity
59. Which of the following immunoglobulin is called reaginic antibody ?
- (A) IgG
 - (B) IgD
 - (C) IgE
 - (D) IgM
60. Which among the following is produced almost exclusively by activated helper T Cells ?
- (A) Interleukin 2 (IL2)
 - (B) Histamine
 - (C) Immunoglobulin
 - (D) Anaphylatoxins

ROUGH WORK

ENTRANCE TEST-2022**SCHOOL OF BIOLOGICAL SCIENCES****NANOTECHNOLOGY**

Question Booklet Series

A

Total Questions : 60

Time Allowed : 70 Minutes

Roll No. :

--	--	--	--	--	--

Instructions for Candidates :

1. Write your Entrance Test Roll Number in the space provided at the top of this page of Question Booklet and fill up the necessary information in the spaces provided on the OMR Answer Sheet.
2. OMR Answer Sheet has an Original Copy and a Candidate's Copy glued beneath it at the top. While making entries in the Original Copy, candidate should ensure that the two copies are aligned properly so that the entries made in the Original Copy against each item are exactly copied in the Candidate's Copy.
3. All entries in the OMR Answer Sheet, including answers to questions, are to be recorded in the Original Copy only.
4. Choose the correct / most appropriate response for each question among the options A, B, C and D and darken the circle of the appropriate response completely. The incomplete darkened circle is not correctly read by the OMR Scanner and no complaint to this effect shall be entertained.
5. Use only blue/black ball point pen to darken the circle of correct/most appropriate response. In no case gel/ink pen or pencil should be used.
6. Do not darken more than one circle of options for any question. A question with more than one darkened response shall be considered wrong.
7. There will be '**Negative Marking**' for wrong answers. Each wrong answer will lead to the deduction of 0.25 marks from the total score of the candidate.
8. Only those candidates who would obtain positive score in Entrance Test Examination shall be eligible for admission.
9. Do not make any stray mark on the OMR sheet.
10. Calculators and mobiles shall not be permitted inside the examination hall.
11. Rough work, if any, should be done on the blank sheets provided with the question booklet.
12. OMR Answer Sheet must be handled carefully and it should not be folded or mutilated in which case it will not be evaluated.
13. Ensure that your OMR Answer Sheet has been signed by the Invigilator and the candidate himself/herself.
14. At the end of the examination, hand over the OMR Answer Sheet to the invigilator who will first tear off the original OMR sheet in presence of the Candidate and hand over the Candidate's Copy to the candidate.

SEAL

(Chemistry)

1. Lithium Fluoride's lattice energy to Magnesium oxide conceptually should be :

- (A) Lesser
- (B) Larger
- (C) Same
- (D) Cannot be predicted

2. Distance at which attractive forces overcome repulsive forces in hydrogen molecule :

- (A) Half the covalent radius of hydrogen atom
- (B) Mean of the covalent radii of two hydrogen atoms
- (C) Half of the bond length of dihydrogen molecule
- (D) Double the covalent radius of hydrogen atom

3. Allred-Rochow electronegativity of an element is :

- (I) Directly proportional to the effective nuclear charge
- (II) Directly proportional to the covalent radius
- (III) Inversely proportional to the square of the covalent radius
- (IV) Directly proportional to the square of the effective nuclear charge

The correct answer is :

- (A) (I) and (II)
- (B) (I) and (III)
- (C) (II) and (III)
- (D) (I) and (IV)

4. According to Bent's rule, for p-block elements, the correct combination of geometry around the central atom and position of more electro- negative substituent is :

- (A) Trigonal bipyramidal and axial
- (B) Trigonal bipyramidal and equatorial
- (C) Square pyramidal and axial
- (D) Square pyramidal and basal

5. In van der Waals equation, which of the following statements is/are correct ?

- (A) The coefficient "a" account for the mutual attraction between the molecules
- (B) The term a/v^2 increases the pressure of real gas relative to ideal gas
- (C) The coefficient "b" represents the volume that is compressible
- (D) Both (B) and (C)

6. Which among the following has highest surface tension ?

- (A) Octane
- (B) Water
- (C) Glycerol
- (D) Dodecane

7. Which of the following is correct for RMS velocity, average velocity and most probable velocity of gas at a given temperature ?

- (A) $\text{RMS velocity} > \text{average velocity} > \text{most probable velocity}$
- (B) $\text{Average velocity} > \text{RMS velocity} > \text{most probable velocity}$
- (C) $\text{RMS velocity} = \text{average velocity} > \text{most probable velocity}$
- (D) $\text{Most probable velocity} > \text{average velocity} > \text{RMS velocity}$

8. The Miller indices of the plane for which interplanar spacing is equal to the half of the dimensions of the cubic unit cell would be :

- (A) 111
- (B) 100
- (C) 200
- (D) 222

SEAL

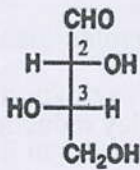
9. For electronic spectra of K_2CrO_4 (I) and K_2MoO_4 (II), the correct combination is :
- (A) Transition is d-d and λ_{max} for (I) < (II)
 (B) Transition is LMCT and λ_{max} for (I) < (II)
 (C) Transition is LMCT and λ_{max} for (I) > (II)
 (D) Transition is MLCT and λ_{max} for (I) > (II)
10. High spin complex of a 3d metal ion M has a magnetic moment of 2.9 B.M. in octahedral coordination environment and 4.1 B.M. in tetrahedral environment. The M ion can be ?
- (A) Co^{III}
 (B) Ni^{II}
 (C) Cu^{II}
 (D) Co^{II}
11. Which of the following is incorrect in case of boron clusters ?
- (A) $B_6H_6^{2-}$ is closo-type and the 6 B's lie on the corners of a octahedron
 (B) B_5H_9 is nido-type and the 5 B's lie on the corners of a square pyramid
 (C) B_4H_{10} is arachno-type and the 4 B's lie on the corners of an octahedron where two corners are removed
 (D) $B_6H_6^{2-}$ is nido-type and the 6 B's lie on the corners of an octahedron
12. For magnesium complex of $EDTA^{2-}$, the number of N-donor and O-donor centers, are respectively :
- (A) Two and four
 (B) Two and two
 (C) Two and six
 (D) Two and eight
13. The geometry of carbanion is :
- (A) Linear
 (B) Pyramidal
 (C) Tetrahedral
 (D) Trigonal planar
14. What is the correct configuration at C2 and C3 of the following molecule ?
- 
- (A) 2S,3S
 (B) 2R,3R
 (C) 2S,3R
 (D) 2R,3S
15. In the π molecular orbital diagram of benzene, the number of pairs of degenerate orbitals is :
- (A) 1
 (B) 2
 (C) 6
 (D) 4
16. The potential energy of cyclohexane is minimum for _____ conformation.
- (A) Chair
 (B) Twist boat
 (C) Boat
 (D) Half-chair
17. As substituents in electrophilic aromatic substitutions, halogens are :
- (A) Deactivating ortho-/para-directors
 (B) Deactivating meta-directors
 (C) Activating ortho-/para-directors
 (D) Activating meta-directors
18. For the SN_1 reaction of tert-butyl chloride with hydroxyl ion :
- $$CH_3)_3C-Cl + OH^- \rightarrow (CH_3)_3C-OH + Cl^-$$
- if the concentration of hydroxyl ion is doubled, the rate of formation of tert-butanol will :
- (A) Double
 (B) Increase four times
 (C) Remain the same
 (D) Decrease

19. The reduction of base-labile aldehydes or ketones to alkanes can be achieved by :
- Clemmensen reduction
 - Wolff Kishner reduction
 - Meerwein-Ponndorf-Verley reduction
 - Bouveault-Blanc reduction
20. Which of the following will not undergo Hell-Volhard-Zelinsky reaction ?
- Acetic acid
 - Propionic acid
 - 2-Methyl propionic acid
 - Formic acid
21. Which of the following is not the state function ?
- Heat
 - Heat+Work
 - Entropy
 - Gibbs free energy
22. Which of the following statement is/are CORRECT ?
- Kirchoff's equation gives the temperature dependence of enthalpy of a reaction.
 - Residual entropy of carbon monoxide is not zero
 - The total entropy of universe increases during an irreversible process.
- (1) and (2)
 - (2) and (3)
 - (1) and (3)
 - (1), (2) and (3)
23. _____ is a pH indicator electrode.
- Quinhydrone electrode
 - Calomel electrode
 - Silver-silver chloride electrode
 - Zinc electrode
24. At the triple point of water, the number of degrees of freedom for the system is :
- 3
 - 2
 - 1
 - 0
25. Which of the following thermodynamic laws allows us to calculate absolute entropy of a substance ?
- Zeroth law of Thermodynamics
 - First law of Thermodynamics
 - Second law of Thermodynamics
 - Third law of Thermodynamics
26. Consider the following statements :
- Half life period of first order reaction is independent of initial concentration of reactants.
 - Zero order reaction takes finite time for completion.
 - Rate constant of a first order reaction is dimensionless.
- Which of the above statement(s) is/are correct ?
- (1) & (2)
 - (2) & (3)
 - (1) & (3)
 - (1), (2) & (3)

27. For a reaction, $A(g) + 2B(g) \rightarrow C(g) + D(g)$, the rate law is $dx/dt = k [A][B]$. The rate of reaction will _____ compared to initial rate when the concentration of A is doubled and simultaneously concentration of B is halved.
- (A) Remain the same
(B) Become double
(C) Become 4 times
(D) Nothing can be said as the given information is inadequate
28. Which of the following solutions of an electrolyte has the highest equivalent conductance ?
- (A) 0.2 N
(B) 0.02 N
(C) 2 N
(D) 0.002N
29. The molar solubility of $PbBr_2$ is 2×10^{-3} M at a certain temperature. What will be K_{sp} for $PbBr_2$?
- (A) 8.0×10^{-6}
(B) 0.4×10^{-8}
(C) 3.2×10^{-8}
(D) 4.0×10^{-6}
30. Identify incorrect statement for paper chromatography :
- (A) It is a liquid-liquid partitioning chromatography
(B) It involves water as stationary Phase
(C) It involves paper as stationary phase
(D) For effective separation R_f value should be greater than zero but less than 1
31. What is incorrect match in volumetric analysis ?
- (A) Permanganometry-redox titration
(B) Argentometry-precipitation titration
(C) Iodometry-precipitation titration
(D) EDTA-Complexometric titration
32. To the cobaltous chloride solution ethylene diamine ligand was added in excess followed by stoichiometric amount of H_2O_2 and conc. HCl to form a green complex. This complex on reaction to $AgNO_3$ will precipitate :
- (A) One equivalent of ionisable chloride
(B) Two equivalents of ionisable chloride
(C) Three equivalents of ionisable chloride
(D) The compound is inert and does not react with $AgNO_3$

(Physics)

33. For two vectors \vec{a} and \vec{b} , if the scalar product of $\vec{a} \cdot \vec{b} \geq 0$, then which of the following is true about the angle between the two vectors ?
- (A) $0 < \theta < \frac{\pi}{2}$
(B) $0 < \theta < \pi$
(C) $0 \leq \theta \leq \pi$
(D) $0 \leq \theta \leq \frac{\pi}{2}$
34. Lorentz transformation equations hold for :
- (A) Non-relativistic velocities only
(B) Relativistic velocities only
(C) Non-relativistic as well as relativistic velocities
(D) Photons only
35. When the speed of an object reaches the speed of light, the length of the object changes to :
- (A) Half the original length
(B) Double the original length
(C) Infinite
(D) Zero
36. The instantaneous displacement of a particle of mass m executing SHM under a force constant k is $x = A \sin(\omega t + \phi)$ where $\omega = \sqrt{\frac{k}{m}}$. The time average of kinetic energy over a Time period T is :
- (A) $\frac{1}{4} kA^2$
(B) $\frac{1}{3} kA^2$
(C) $\frac{1}{2} kA^2$
(D) kA^2
37. Which of the following cannot be calculated using Gauss law ?
- (A) Electric field intensity
(B) Electric flux density
(C) Charge
(D) Permittivity
38. According to the Faraday's law of electromagnetic induction :
- (A) Electric field is produced by time varying magnetic flux
(B) Magnetic field is produced by time varying electric flux
(C) Magnetic field is associated with moving charge
(D) None of these
39. The value of conduction current in an empty space is :
- (A) Zero
(B) Unity
(C) Infinite
(D) None of these
40. Dimensions of Poynting vector are same as that of :
- (A) Power
(B) Power/Area
(C) Volt/meter
(D) Energy
41. The sum of internal energy and the product of pressure and volume is known as :
- (A) Entropy
(B) Enthalpy
(C) Gibb's free energy
(D) Specific Heat

42. For any irreversible process, the entropy change is :
- Positive
 - Zero
 - Negative
 - Infinite
43. The wavelength of radiation emitted by a body depends upon :
- Nature of its surface
 - Area of its surface
 - Temperature of its surface
 - None of these
44. The ratio of specific heats for a diatomic gas is equal to :
- 7/5
 - 5/4
 - 6/7
 - 7/2
45. If the two input waveforms of equal amplitude and 90 degree phase difference are applied to the CRO then the Lissajous patterns obtained will be :
- Ellipse
 - Circle
 - Straight line tilted at 45 degree w.r.t x-axis
 - Vertical straight line
46. For a wave having group velocity of 3×10^6 m/s, the phase velocity in order of 10^8 m/s
- 120
 - 130
 - 140
 - 150
47. Which of the following represents kinetic viscosity ?
- Viscosity/temperature
 - Viscosity/density
 - Viscosity/area
 - Viscosity/mass
48. In a single slit (of width $1.2 \mu\text{m}$) diffraction experiment, the angular width of the central maxima is $\pi/6$. The wavelength of light in this case is :
- 6 Å
 - 60 Å
 - 600 Å
 - 6000 Å
49. The Compton shift $\Delta\lambda$ is twice the Compton wavelength if the scattering angle is :
- 0°
 - 45°
 - 90°
 - 180°
50. The de Broglie wavelength of an electron accelerated by a potential of 150V is :
- 0.28 Å
 - 1 Å
 - 15 Å
 - 150 Å
51. Which of the following can be proved on the basis of uncertainty principle ?
- Protons exist inside the nucleus
 - Neutrons exist inside the nucleus
 - Electrons do not exist inside the nucleus
 - None of these

52. Tunnel effect is notably observed in the case of :
- X rays
 - Gamma rays
 - Alpha particles
 - Beta particles
53. Which of the following properties of the Sun is studied using Zeeman effect ?
- Magnetic fields
 - Electric fields
 - Solar flares
 - Sun spots
54. The dipole magnetic moment is directly proportional to the nuclear spin. Which of the following is the constant of proportionality ?
- Planck's constant
 - Gyromagnetic ratio
 - Nuclear susceptibility
 - None of these
55. Baryon and mesons are collectively referred to as :
- Leptons
 - Partons
 - Hadrons
 - Pomerons
56. The masses of neutron and proton are 1.0087 a.m.u and 1.0073 a.m.u respectively. When the two combine to form a helium nucleus of mass 4.0015 a.m.u. The binding energy of the helium nucleus will be :
- 284 MeV
 - 28.4 MeV
 - 2.84 MeV
 - 0.284 MeV
57. In which of the following Bravais lattice, not all axial angles are right angles ?
- Tetrahedral
 - Rhombohedral
 - Orthorhombic
 - Cubic
58. The specific heat at constant volume is given by :
- $C_v = \frac{\gamma R}{\gamma + 1}$
 - $C_v = \frac{\gamma R}{\gamma - 1}$
 - $C_v = \frac{R}{\gamma + 1}$
 - $C_v = \frac{R}{\gamma - 1}$
59. What is meant by the expression "the first Brillouin zone" ?
- The Wigner Seitz cell of the reciprocal lattice
 - The Bravais lattice of a reciprocal lattice
 - The area in reciprocal space that is enclosed by the Fermi energy
 - The Wigner Seitz cell in hexagonal lattices
60. In RC coupled amplifier, the voltage gain over mid frequency range :
- Changes abruptly with frequency
 - Is constant
 - Changes uniformly with frequency
 - None of these

OR
(Biology)

33. Starch and glycogen are both polymers of :
- (A) β -D-glucose with β -(1 \rightarrow 4) and β -(1 \rightarrow 6) linkages
 - (B) α -D-glucose with α -(1 \rightarrow 4) and α -(1 \rightarrow 6) linkages
 - (C) α -D-glucose with α -(1 \rightarrow 4) linkages only
 - (D) β -D-glucose with β -(1 \rightarrow 4) linkages only
34. The area of allowed regions in the Ramachandran map will be least for :
- (A) Glycine
 - (B) L-Alanine
 - (C) L-Proline
 - (D) α -methyl L-Valine
35. Which vitamin is derived from cholesterol ?
- (A) A
 - (B) B₁₂
 - (C) D
 - (D) K
36. An enzyme with a high K_m has :
- (A) Low affinity for its substrate and requires greater concentration of substrate to achieve V_{max}
 - (B) High affinity for its substrate and requires smaller concentration of substrate to achieve V_{max}
 - (C) Low affinity for its substrate and is always independent of substrate concentration to achieve V_{max}
 - (D) A high affinity for its substrate and is always independent of substrate concentration to achieve V_{max}
37. Which of the following organelles is enclosed by a single membrane system ?
- (A) Nucleus
 - (B) Mitochondria
 - (C) Endoplasmic reticulum
 - (D) Chloroplasts
38. The post-mitotic phase during which active synthesis of RNA and proteins occurs is the :
- (A) M-phase
 - (B) S-phase
 - (C) G-1 phase
 - (D) G-2 phase
39. In a bacterial cell wall, the peptidoglycan structure contains :
- (A) D-amino acids only
 - (B) L-amino acids only
 - (C) Both D- and L-amino acids
 - (D) None of the above
40. Virion is a :
- (A) Complete virus particle with nucleic acid surrounded by a capsid
 - (B) Virus particle with nucleic acid only
 - (C) Virus particle with capsid only
 - (D) None of the above
41. Which of the following is not a component of the DNA backbone ?
- (A) Pentose sugar
 - (B) Phosphate
 - (C) Phosphodiester bond
 - (D) Nitrogenous bases

42. Which of the following is incorrectly paired ?
- (A) Lac Z-Transacetylase
 - (B) Lac Y-Permease
 - (C) Lac de-repressor-Allolactose
 - (D) B-galactosidase substrate-lactose
43. Deletion and insertion mutations in DNA that cause frame shift mutations, hampers the end product of which of the following processes ?
- (A) Replication
 - (B) Transcription
 - (C) Translation
 - (D) RNA processing
44. Proofreading by DNA polymerase III requires :
- (A) 5' to 3' exonuclease activity
 - (B) 3' to 5' exonuclease activity
 - (C) 5' to 3' endonuclease activity
 - (D) 3' to 5' endonuclease activity
45. Which of the following vectors has the lowest carrying capacity ?
- (A) Cosmids
 - (B) Plasmids
 - (C) BACs
 - (D) YACs
46. Which of the following statements is NOT TRUE ?
- (A) Type II endonucleases are most commonly used enzymes in gene cloning
 - (B) Type II endonucleases have palindromic recognition and cleavage sequences
 - (C) Type II endonucleases require ATP and S-adenosyl methionine as cofactor
 - (D) Both (A) and (B)
47. Which of the following temperature conditions in a PCR cycle is reaction specific ?
- (A) Annealing temperature
 - (B) Denaturation temperature
 - (C) Extension temperature
 - (D) All of the above
48. Which of the following is an 8-cutter Type II restriction endonuclease ?
- (A) BamHI
 - (B) Not I
 - (C) Xho I
 - (D) EcoRI
49. Which of the following statements is not true about Ethidium bromide ?
- (A) A non-polar dye to stain DNA molecules
 - (B) It fluoresces orange red color when exposed to UV light
 - (C) It intercalates between DNA bases and as a result its fluorescence intensity increases 15-20-fold
 - (D) Due to its DNA binding capability, it is reasoned to act as a potential mutagen
50. Which of the following acts as a reducing agent in SDS-PAGE ?
- (A) SDS
 - (B) Ammonium Persulphate
 - (C) TEMED
 - (D) Dithiothreitol

51. Which of the following is the correct sequence for a Western Blotting procedure ?
- (1) Incubation with conjugated secondary antibody
 - (2) Transferring proteins on to a membrane
 - (3) Blocking the non-specific interactions
 - (4) Incubating with primary antibody
- (A) (1), (2), (3), (4)
 - (B) (2), (3), (4), (1)
 - (C) (4), (1), (2), (3)
 - (D) (2), (4), (3), (1)
52. Which of the following ELISA types is used to determine the concentration of small molecules in a biological sample ?
- (A) Direct
 - (B) Indirect
 - (C) Sandwich
 - (D) Competitive
53. Which of the following serves as the main high-energy phosphate reserve in vertebrate muscle ?
- (A) ATP
 - (B) Creatine phosphate
 - (C) Phosphoenol pyruvate
 - (D) Glyceraldehyde-3-phosphate
54. Which of the following is NOT an enzyme of the Hexose Monophosphate Shunt ?
- (A) Glyceraldehyde-3-phosphate dehydrogenase
 - (B) Glucose-6-phosphate-dehydrogenase
 - (C) Transketolase
 - (D) Phosphogluconate Dehydrogenase
55. In fatty acid β -oxidation which enzyme converts the long-chain acylcarnitine to long-chain acyl-CoA in the inner mitochondrial membrane ?
- (A) Carnitine palmitoyltransferase (CPT1)
 - (B) Carnitine palmitoyltransferase (CPT2)
 - (C) Carnitine translocase (CAT)
 - (D) None of the above
56. Which of the following is/are involved for the transport of nitrogen of amino acids from tissues to liver and into the urea cycle ?
- (A) Transamination
 - (B) Oxidative deamination
 - (C) Hydrolytic deamination
 - (D) All of the above
57. A child presented to a clinic with severe wheeze and symptoms of Asthma. Which of the following blood cells can be expected to be elevated in complete blood count ?
- (A) Basophils
 - (B) Neutrophils
 - (C) Eosinophils
 - (D) Monocytes
58. Antigen-antibody interaction does not involve any one of the following ?
- (A) Covalent bond
 - (B) Hydrogen bond
 - (C) Electrostatic interaction
 - (D) Hydrophobic interaction
59. mRNA vaccines for COVID-19 work in which one of the following ways ?
- (A) mRNA direct the human cell to make viral proteins
 - (B) mRNA restrict viral entry into human cells
 - (C) mRNAs code for small peptides that bind SARS-nCoV and render it ineffective
 - (D) mRNAs code for antibodies against viral proteins
60. What happens to the Immune system in Auto-immune disorders ?
- (A) Immune cells die
 - (B) Immune system makes too many immune cells
 - (C) Immune system mistakenly recognizes body tissues as foreign
 - (D) None of the above

Sr. No.

ENTRANCE TEST-2021

SCHOOL OF BIOLOGICAL SCIENCES

NANOTECHNOLOGY

Total Questions : 60
Time Allowed : 70 Minutes

Question Booklet Series

A

Roll No. :

--	--	--	--	--	--

Instructions for Candidates :

1. Write your Entrance Test Roll Number in the space provided at the top of this page of Question Booklet and fill up the necessary information in the spaces provided on the OMR Answer Sheet.
2. OMR Answer Sheet has an Original Copy and a Candidate's Copy glued beneath it at the top. While making entries in the Original Copy, candidate should ensure that the two copies are aligned properly so that the entries made in the Original Copy against each item are exactly copied in the Candidate's Copy.
3. All entries in the OMR Answer Sheet, including answers to questions, are to be recorded in the Original Copy only.
4. Choose the correct / most appropriate response for each question among the options A, B, C and D and darken the circle of the appropriate response completely. The incomplete darkened circle is not correctly read by the OMR Scanner and no complaint to this effect shall be entertained.
5. Use only blue/black ball point pen to darken the circle of correct/most appropriate response. In no case gel/ink pen or pencil should be used.
6. Do not darken more than one circle of options for any question. A question with more than one darkened response shall be considered wrong.
7. There will be '**Negative Marking**' for wrong answers. Each wrong answer will lead to the deduction of 0.25 marks from the total score of the candidate.
8. Only those candidates who would obtain positive score in Entrance Test Examination shall be eligible for admission.
9. Do not make any stray mark on the OMR sheet.
10. Calculators and mobiles shall not be permitted inside the examination hall.
11. Rough work, if any, should be done on the blank sheets provided with the question booklet.
12. OMR Answer Sheet must be handled carefully and it should not be folded or mutilated in which case it will not be evaluated.
13. Ensure that your OMR Answer Sheet has been signed by the Invigilator and the candidate himself/herself.
14. At the end of the examination, hand over the OMR Answer Sheet to the invigilator who will first tear off the original OMR sheet in presence of the Candidate and hand over the Candidate's Copy to the candidate.

Part—A : Chemistry

- At NTP (293.15K, 1atm), 10 g of a gas occupies 2 litre. At what temperature will the volume become double, at the same pressure and for the same quantity of gas ?
 - 293.15 K
 - 293.15°C
 - 586.30 K
 - 586.30 °C
- If the mean free path of a gas at 760 torr is λ , what will be its value at 5 atm pressure ?
 - $\lambda/5$
 - 5λ
 - $5\lambda/760$
 - λ^2
- The temperature at which the second virial coefficient of a real gas is zero is called :
 - Critical temperature
 - Boiling point
 - Boyle temperature
 - Eutectic point
- Which of the following is correct ?
 - Coefficient of Viscosity of liquids increases with increasing temperature, while that of gases decreases with temperature
 - Coefficient of Viscosity of liquids decreases with increasing temperature, while that of gases increases with temperature
 - Coefficient of Viscosity of both, liquids and gases, decreases with increasing temperature
 - Coefficient of Viscosity of both, liquids and gases, increases with increasing temperature
- The rise of a liquid in a capillary tube is due to :
 - Surface Tension
 - Osmosis
 - Diffusion
 - Viscosity
- For the ideal gas, the maximum work produced in the reversible isothermal expansion from volume V_1 to volume V_f is given by :
 - $nRT \ln (V_f/V_1)$
 - $-C_v (T_2-T_1)$
 - $-\Delta U-Q$
 - $-nRT \ln (V_f/V_1)$
- In which of the following cases the reaction is not spontaneous ?
 - ΔH is positive and ΔS is also positive ($T\Delta S > \Delta H$)
 - ΔH is negative and ΔS is also negative ($-T\Delta S < -\Delta H$)
 - ΔH is positive and ΔS is negative
 - ΔH is negative and ΔS is positive
- Helmholtz Free energy A is expressed as :
 - $A = U+TS$
 - $A = H+TS$
 - $A = H-TS$
 - $A = U-TS$
- ΔG° is related to equilibrium constant by :
 - $\Delta G^\circ = -RT \ln K$
 - $\Delta G^\circ = -RT \ln (1/K)$
 - $\Delta G^\circ = RT \log K$
 - $\Delta G^\circ = -RT (1/\ln K)$

10. For a system of water and water vapor co-existing in equilibrium the number of degree of freedom is :
- (A) 1
(B) 2
(C) 3
(D) 4
11. The ratio of the ionic mobilities of M^+ and X^- ions is 0.75. If the speed of M^+ ions is found to be $3.0 \mu\text{m s}^{-1}$; the speed of X^- ions is ?
- (A) $1.3 \mu\text{m s}^{-1}$
(B) $2.3 \mu\text{m s}^{-1}$
(C) $2.5 \mu\text{m s}^{-1}$
(D) $4.0 \mu\text{m s}^{-1}$
12. If for a solution of an electrolyte, t_+ is the transport number of the cation, then the transport number of the anion t_- is equal to :
- (A) $t_+/2$
(B) $1+t_+$
(C) $1-t_+$
(D) $(1-t_+)/2$
13. The transference number of an ion :
- (A) Is always positive
(B) Is always negative
(C) Can be positive as well as negative
(D) Is always zero
14. Free energy change (ΔG) is related to the e.m.f of a cell (E) as :
- (A) $\Delta G = - (RT/nF) \ln E$
(B) $\Delta G = - nFE/RT$
(C) $\Delta G = - nFE$
(D) $E = -nFE$
15. Zinc is coated over iron to prevent rusting of iron because :
- (A) It is cheaper than iron
(B) $E^\circ (\text{Zn}^{2+}, \text{Zn}) = E^\circ (\text{Fe}^{2+}, \text{Fe})$
(C) $E^\circ (\text{Zn}^{2+}, \text{Zn}) > E^\circ (\text{Fe}^{2+}, \text{Fe})$
(D) $E^\circ (\text{Zn}^{2+}, \text{Zn}) < E^\circ (\text{Fe}^{2+}, \text{Fe})$
16. The molecular geometry of BF_3 and SF_6 is :
- (A) Both trigonal planar
(B) Both trigonal pyramidal
(C) Trigonal planar and Octahedral, respectively
(D) Trigonal pyramidal and trigonal planar, respectively
17. Lattice Energy of ionic compound is calculated by using :
- (A) Hess's Law
(B) Kirchoff's equation
(C) Born-Haber cycle
(D) Carnot cycle

18. Which one of the atoms listed below has the largest value for its electron affinity ?
- (A) O
(B) He
(C) Cr
(D) F
19. For which one of the processes below is ΔH largest in magnitude ?
- (A) $\text{Be}^+(g) \rightarrow \text{Be}^{2+}(g) + e^-$
(B) $\text{Be}^{2+}(g) \rightarrow \text{Be}^{3+}(g) + e^-$
(C) $\text{B}^{2+}(g) \rightarrow \text{B}^{3+}(g) + e^-$
(D) $\text{C}(g) \rightarrow \text{C}^+(g) + e^-$
20. In accordance with Fajan's rules, the covalent character in ionic compounds will be :
- (A) Large in case of small charge on the cation, large size of cation and small size on anion
(B) Small in case of high charge on the cation, small size of cation and large size on anion
(C) Large in case of high charge on the cation, small size of cation and large size on anion
(D) Cannot be predicted
21. The systematic name of $[\text{Co}(\text{en})_2\text{Cl}_2]\text{NO}_3$ is :
- (A) Dichlorobis(ethylenediamine)cobaltate(II) nitrate
(B) Bis(ethylenediamine) dichlorocobalt(III) nitrate
(C) Bis(ethylenediamine) dichlorocobalt(II) nitrate
(D) Dichlorobis(ethylenediamine)cobalt(III) nitrate
22. The CFSE of $[\text{Co}(\text{NH}_3)_6]^{3+}$:
- (A) $-0.4\Delta_0$
(B) $-1.2\Delta_0$
(C) $-2.4\Delta_0 (+2P)$
(D) $-1.8\Delta_0 (+3P)$
23. The value of the spin-only magnetic moment (μ_{eff}) for $[\text{Cr}(\text{NH}_3)_6]^{3+}$ is :
- (A) 0
(B) 3.87 BM
(C) 4.90 BM
(D) 5.92 BM
24. The ligand field strength is in order of $\text{CN}^- > \text{NH}_3 > \text{H}_2\text{O}$. So the relative size of CFSE (Δ) and energy of light absorbed will be :
- (A) $[\text{Ti}(\text{NH}_3)_6]^{3+} > [\text{Ti}(\text{H}_2\text{O})_6]^{3+} > [\text{Ti}(\text{CN})_6]^{3-}$
(B) $[\text{Ti}(\text{CN})_6]^{3-} > [\text{Ti}(\text{NH}_3)_6]^{3+} > [\text{Ti}(\text{H}_2\text{O})_6]^{3+}$
(C) $[\text{Ti}(\text{CN})_6]^{3-} > [\text{Ti}(\text{H}_2\text{O})_6]^{3+} > [\text{Ti}(\text{NH}_3)_6]^{3+}$
(D) $[\text{Ti}(\text{H}_2\text{O})_6]^{3+} > [\text{Ti}(\text{NH}_3)_6]^{3+} > [\text{Ti}(\text{CN})_6]^{3-}$
25. Which of the carbocations will be most stable ?
- (A) Vinyl carbocation
(B) Cyclopropyl carbocation
(C) Trimethyl carbocation
(D) Phenyl carbocation
26. Which of the following structures represent the same stereoisomer ?

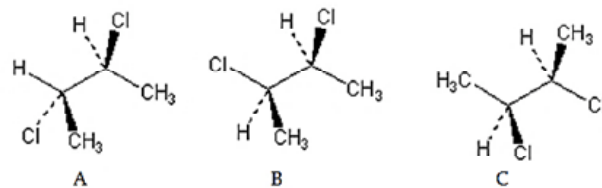

- (A) A and B
(B) B and C
(C) A, B and C
(D) A and C

27. Which of the following compounds is not aromatic? 30. Identify the product(s) formed in the following reaction :

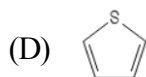
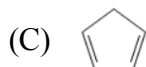
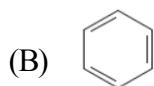
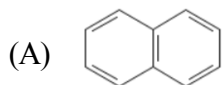

28. What type of reaction do alkynes undergo across the triple bond ?

- (A) Elimination reaction
 (B) Substitution reaction
 (C) Addition reaction
 (D) Halogenation

29. Identify the correct product(s) formed :

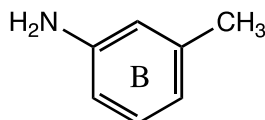
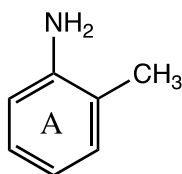
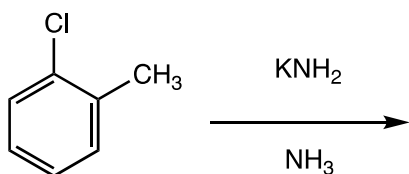

- (A) A
 (B) B
 (C) A and B
 (D) None of these

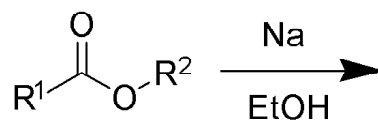

- (A) R^1-CH_2-OH
 (B) R^2-OH
 (C) Both (A) and (B)
 (D) None of these

31. Which of these compounds is most reactive towards electrophilic aromatic substitution ?

- (A) Benzene
 (B) Phenol
 (C) Toluene
 (D) Nitrobenzene

32. What reagents would you use to complete Nitration of benzene ?

- (A) Conc. HNO_3 + conc. H_2SO_4
 (B) Conc. HNO_3
 (C) Anhydrous $AlCl_3$ + $Ph-NO_2$
 (D) Conc. H_2SO_4 + Oleum

Part—B: Biology

33. Which of the following proteins contains quaternary structure ?
- (A) Myoglobin
 - (B) Insulin
 - (C) Chymotrypsin
 - (D) Hemoglobin
34. Which one of the following substance represents carbohydrate ?
- (A) Glycerol
 - (B) Sucrose
 - (C) Waxes
 - (D) Sphingomyelin
35. Vitamin, that prevents rupturing of the blood vessels and bleeding is called as :
- (A) Vitamin E
 - (B) Vitamin C
 - (C) Vitamin K
 - (D) Vitamin B₂
36. The hyperchromic effect refers to :
- (A) An increase in the absorbance of light at 260 nm upon denaturation of DNA
 - (B) A change in the optical rotator dispersion of DNA solution upon heating
 - (C) An increase in the absorbance of light at 260 nm upon denaturation of RNA
 - (D) An increase in the absorbance of light at 260 nm when DNA-RNA hybrids are annealed
37. Which cell organelle reduces the number of other organelles ?
- (A) Oxysome
 - (B) Lysosome
 - (C) Mitochondria
 - (D) None of the above
38. Which has a single membrane covering ?
- (A) Mesosomes
 - (B) Golgi apparatus
 - (C) Mitochondria
 - (D) Centrosomes
39. Which of the following characteristic feature resembles in bacteria and viruses ?
- (A) Binary fission
 - (B) Ribosomes in cytoplasm
 - (C) Conjugation
 - (D) Nucleic acid as genetic material
40. Which of the following special class of proteins is responsible for import of Vitamin B₁₂ into gram negative bacteria ?
- (A) Tubulins
 - (B) Porins
 - (C) Integrins
 - (D) Adhesins

41. The minimum length of cistron in base pairs which synthesizes a polypeptide of 50 amino acids is :
- (A) 50 bp
(B) 100 bp
(C) 150 bp
(D) 190 bp
42. The process of coding of the message from DNA to RNA is :
- (A) Replication
(B) Translation
(C) Transcription
(D) Transformation
43. Gene which is responsible for the synthesis of polypeptide chain is called as :
- (A) Promoter gene
(B) Structural gene
(C) Operator gene
(D) Regulator gene
44. How many promoters control the transcription in lac operon of E. Coli ?
- (A) One
(B) Two
(C) Three
(D) Four
45. Which one of the following would not be used in preparing recombinant DNA ?
- (A) Plasmids
(B) Phages
(C) Restriction enzymes
(D) DNA polymerase III
46. Which one of the following DNA polymerase of prokaryotes have both 3-5' and 5-3' exonuclease activity ?
- (A) DNA Pol II
(B) DNA Pol III
(C) DNA Pol I
(D) Both (B) and (C)
47. Which polymerase made widespread use of PCR possible ?
- (A) DNA polymerase I
(B) Taq polymerase
(C) DNA polymerase
(D) Reverse transcriptase
48. In PCR deoxyoligonucleotide :
- (A) Serves as primer
(B) Serves as denaturant
(C) Helping polymerization
(D) Activate Taq polymerase

49. The electrophoresis technique used for the separation of charged molecules was developed by :
- (A) Tiselius
(B) Tswell
(C) Alexander Reuss
(D) Oliver Smithies
50. The force with which the particles must displace the liquid media into which they sediment is called as :
- (A) Fractional force
(B) Buoyant force
(C) Gravitational forces
(D) Drag force
51. Which one of the following technique does not involve electrophoresis for the separation of biomolecules ?
- (A) Dot blotting
(B) Southern blotting
(C) Northern blotting
(D) Western blotting
52. The Southern blotting is the technique used for the detection of:
- (A) Protein
(B) DNA
(C) RNA
(D) Both Protein & DNA
53. Which of the following amino acids are not suitable for gluconeogenesis ?
- (A) Arginine and lysine
(B) Leucine and isoleucine
(C) Lysine and valine
(D) Lysine and leucine
54. DiGeorge syndrome (DS) occurs sporadically due to the deletion in chromosome at position :
- (A) 22q11.2
(B) 22q15.5
(C) 22q111.2
(D) 22q119.2
55. Which of the following substance inhibits the function of enolase enzyme during glycolysis ?
- (A) Iodoacetate
(B) Fluoride
(C) Fluoroacetate
(D) Chloride
56. Which of the following enzyme involved at substrate level phosphorylation during Krebs cycle ?
- (A) Pyruvate kinase
(B) Phosphofructokinase
(C) Succinyl-CoA synthetase
(D) Acetyl-CoA synthetase

57. In higher organisms the cell known for antigen processing is :
- (A) Eosinophil
 - (B) Megakaryocyte
 - (C) T-cell
 - (D) Macrophage
58. How many disulfide bonds are present in a typical immunoglobulin molecule ?
- (A) 2-5
 - (B) 6-9
 - (C) 10-20
 - (D) 25-28
59. Primary lymphoid organs include :
- (A) Thymus and spleen
 - (B) Thymus and bone marrow
 - (C) Thymus, bone marrow and spleen
 - (D) Thymus, bone marrow, spleen and lymph nodes
60. In response to allergens, the cells that release histamine and other vasoactive substances are :
- (A) NK cells
 - (B) Mast cells
 - (C) Macrophages
 - (D) Neutrophils

OR

Part—B: Physics

33. According to Einstein's special theory of relativity, laws of physics can be formulated based on :
- (A) Inertial frame of reference
 - (B) Non inertial frame of reference
 - (C) Both non and inertial frame of reference
 - (D) Quantum state
34. When a particle is moving with a velocity of light c relative to S , its velocity as observed by an observer in the frame S' is :
- (A) Zero
 - (B) $0.5c$
 - (C) $0.75c$
 - (D) c
35. If $A = 2i + 3j$ and $B = -3i + 2j$, the cross product of A and B is :
- (A) $5j$
 - (B) $5i$
 - (C) $13k$
 - (D) $-5k$
36. A stone of mass m tied to a string of length L is rotating along a circular path with constant speed v . The torque on the stone is :
- (A) $\frac{mv^2}{L}$
 - (B) Zero
 - (C) $\frac{mv}{L}$
 - (D) $\frac{m}{L}$
37. The magnetic field due to current elements depends upon which of the following factors ?
- (A) Current flowing through it
 - (B) Distance from it
 - (C) Its length
 - (D) All of the above
38. "Total electric flux through any closed surface is equal to the charge enclosed by that surface." This is :
- (A) Gauss's law
 - (B) Lenz's law
 - (C) Maxwell's law
 - (D) Faraday's law
39. The power in an electromagnetic wave with electric field and magnetic field intensities 12 and 6 respectively is :
- (A) 48
 - (B) 12
 - (C) 36
 - (D) 8
40. The Biot-Savart's law is a general modification of :
- (A) Kirchoff's law
 - (B) Ampere's law
 - (C) Lenz's law
 - (D) Faraday's law

41. One kg of ice at 0°C is melted and converted to water at 0°C . The change in entropy is :
- (A) 29.3 cal/k
 (B) 2.93 cal/k
 (C) 2930 cal/k
 (D) 293 cal/k

42. In an ideal diatomic gas at an absolute temperature T , the internal energy per mole is equal to :

- (A) $\frac{5}{2}RT$
 (B) $\frac{3}{2}RT$
 (C) $\frac{3}{4}RT$
 (D) $\frac{1}{2}RT$

43. A thermodynamical system undergoes a cyclic process as shown in figure. Work done in one complete cycle is :

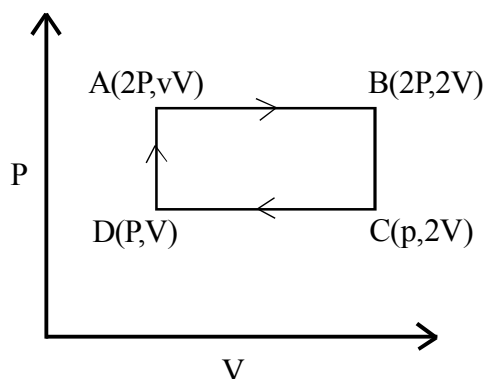

- (A) $2PV$
 (B) $PV/2$
 (C) PV
 (D) Zero

44. According to Stefan-Boltzman law a thermal radiation for perfect radiator, the rate of radiant energy per unit area is proportional to :

- (A) The temperature of that radiator
 (B) The fourth power of the temperature of that radiator
 (C) The square of the temperature of the radiator
 (D) The cube of the temperature of that radiator

45. If two SHMs (with same frequency) acting simultaneously on a particle are given by the equations $y_1 = 2 \sin\left(\omega t + \frac{\pi}{6}\right)$, $y_2 = 3 \sin\left(\omega t + \frac{\pi}{3}\right)$

then the resultant amplitude will be equal to :

- (A) 4.939
 (B) 4.859
 (C) 4.975
 (D) 4.639

46. When two or more notes are sounded simultaneously, the combined note, producing a pleasant effect on the ear is called :

- (A) Melody
 (B) Discord
 (C) Harmony
 (D) Diatonic

47. The monochromatic source of light in Young's double-slit experiment is replaced by a white-light source, now :

- (A) No fringes will be formed
 (B) There will be central white fringe only
 (C) There will be a coloured central fringe only
 (D) There will be central white fringe flanked on either side by a few coloured fringes

48. The overlapping of waves into the regions of geometrical shadow is :
- (A) Dispersion
(B) Polarization
(C) Interference
(D) Diffraction
49. Photoelectric current is of the order of :
- (A) 10^6 A
(B) 10^{-6} A
(C) 10^3 A
(D) 10^{-3} A
50. Let uncertainty be $\Delta x \Delta p = h$. If the size of nucleus is 10^{-15} m, the uncertainty in the momentum of proton remaining within the nucleus is of the order of ($h = 6.62 \times 10^{-34}$ J.sec) :
- (A) 6.62×10^{-19} kg m/s
(B) 6.62×10^{-49} kg m/s
(C) 10^{-23} kg m/s
(D) 6.62×10^{-29} kg m/s
51. The energies of a particle in box are given by :
- (A) Continuous spectrum
(B) $\frac{n^2 h^2}{8ml^2}$
(C) $\frac{\pi^2 h^2}{8ml^2}$
(D) $\frac{nh}{4l\pi^2}$
52. According to Schrodinger a particle is equivalent to a :
- (A) A single-wave
(B) Light wave
(C) A wave-packet
(D) Cannot behave as wave
53. If U is an up quark and D a down quark then the composition of a neutron is :
- (A) UUD
(B) UUU
(C) DDD
(D) UDD
54. The Beta-decay is a process where a nucleus alters its ratio to achieve greater stability.
- (A) $\frac{A}{Z}$
(B) $\frac{N}{Z}$
(C) $\frac{Z}{A}$
(D) $\frac{Z}{N}$
55. The threshold energy of gamma rays for Pair Production to take place is :
- (A) > 1.02 Mev
(B) ≥ 1.02 Mev
(C) $= 1.02$ Mev
(D) < 1.02 Mev

56. During a negative Beta-decay :
- (A) A neutron in the nucleus decays emitting an electron
 - (B) An electron is already present within the nucleus is ejected
 - (C) An atomic electron is ejected
 - (D) A part of binding energy of nuclei is converted into an electron

57. As per the rough plot of the electric resistance of a solid. Define whether a material is :

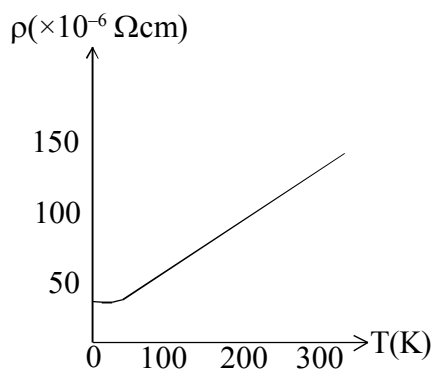

- (A) Insulator
- (B) Metal
- (C) Semiconductor
- (D) Both metal and semiconductor

58. What is Brillouin zone ?
- (A) A region of energy – space that encompasses all of the unique values of energy
 - (B) Another name for the unit cell of the crystal
 - (C) A region of k – space where the group velocity is positive
 - (D) A region of k – space that contains all the unique solutions of the wave equation

59. Thermal runaway is not encountered in FETs because :

- (A) I_{DS} has a negative temperature coefficient
- (B) I_{DS} has a positive temperature coefficient
- (C) I_{DS} has a zero temperature coefficient
- (D) The mobility of the carriers increases with increase in temperature

60. A single stage transistor amplifier with collector load R_C and emitter resistance R_E has d.c. load of :

- (A) R_C
- (B) $R_C + R_E$
- (C) $R_C \parallel R_E$
- (D) $R_C - R_E$

ROUGH WORK

ROUGH WORK

2

Sr. No.137.....

ENTRANCE TEST-2020
SCHOOL OF BIOLOGICAL SCIENCES
NANOTECHNOLOGY

Total Questions : 60

Time Allowed : 70 Minutes

Question Booklet Series

A

Roll No. :

--	--	--	--	--	--

Instructions for Candidates :

1. Write your Entrance Test Roll Number in the space provided at the top of this page of Question Booklet and fill up the necessary information in the spaces provided on the OMR Answer Sheet.
2. OMR Answer Sheet has an Original Copy and a Candidate's Copy glued beneath it at the top. While making entries in the Original Copy, candidate should ensure that the two copies are aligned properly so that the entries made in the Original Copy against each item are exactly copied in the Candidate's Copy.
3. All entries in the OMR Answer Sheet, including answers to questions, are to be recorded in the Original Copy only.
4. Choose the correct / most appropriate response for each question among the options A, B, C and D and darken the circle of the appropriate response completely. The incomplete darkened circle is not correctly read by the OMR Scanner and no complaint to this effect shall be entertained.
5. Use only blue/black ball point pen to darken the circle of correct/most appropriate response. In no case gel/ink pen or pencil should be used.
6. Do not darken more than one circle of options for any question. A question with more than one darkened response shall be considered wrong.
7. There will be '**Negative Marking**' for wrong answers. Each wrong answer will lead to the deduction of 0.25 marks from the total score of the candidate.
8. Only those candidates who would obtain positive score in Entrance Test Examination shall be eligible for admission.
9. Do not make any stray mark on the OMR sheet.
10. Calculators and mobiles shall not be permitted inside the examination hall.
11. Rough work, if any, should be done on the blank sheets provided with the question booklet.
12. OMR Answer Sheet must be handled carefully and it should not be folded or mutilated in which case it will not be evaluated.
13. Ensure that your OMR Answer Sheet has been signed by the Invigilator and the candidate himself/herself.
14. At the end of the examination, hand over the OMR Answer Sheet to the invigilator who will first tear off the original OMR sheet in presence of the Candidate and hand over the Candidate's Copy to the candidate.

SEAL

Part—A : Chemistry

1. Which of the following statements is incorrect ?
- (A) The ground state of an atom will be the one having the greatest spin multiplicity
- (B) The product of the uncertainty in the energy and the life time of an electronic excited state is greater than or equal to $h/4\pi$
- (C) The number of radial nodes of an orbital is equal to the value of n , the principal quantum number
- (D) A radial distribution function (P) gives the probability that an electron will be found at a given distance from the nucleus, regardless of the direction, and is equal to $4\pi r^2 \psi^2$.
2. The number of nodal surfaces and nodal planes in 2p orbital, respectively, are :
- (A) 0 and 1
- (B) 2 and 0
- (C) 1 and 2
- (D) 2 and 1
3. The value of Rydberg constant is $1.0973731568 \times 10^7 \text{ m}^{-1}$ or $1.0973731568 \times 10^9 \text{ cm}^{-1}$. The wavelength of light that is emitted when the electron in hydrogen atom makes a transition from $n = 6$ to $n = 4$ is :
- (A) 1500 nm
- (B) 2050 nm
- (C) 2624 nm
- (D) 3500 nm
4. A laser used as Raman light source has a wavelength of 532 nm. What is the frequency of this light ?
- (A) $2.57 \times 10^8 \text{ Hz}$
- (B) $5.64 \times 10^{14} \text{ Hz}$
- (C) $8.50 \times 10^{16} \text{ Hz}$
- (D) $3.64 \times 10^{18} \text{ Hz}$
5. The molecular geometry of AlCl_3 and PCl_3 is :
- (A) Both trigonal planar
- (B) Both trigonal pyramidal
- (C) Trigonal planar and trigonal pyramidal, respectively
- (D) Trigonal pyramidal and trigonal planar, respectively
6. The Mulliken electronegativity χ_M is given by :
- (A) $\chi_M = 1/2 (I + E_a)$
- (B) $\chi_M = 1/2 (I - E_a)$
- (C) $\chi_M = 1/2 (I + E_a)/Z$
- (D) $\chi_M = 1/2 (I + E_a)/X$
- (I is ionization energy, E_a is electron affinity and Z is the atomic number)
7. The diagonal relationship of elements in the periodic table arises because of similarity in :
- (A) Ionic radii
- (B) Electronic configuration
- (C) Crystal structure
- (D) Charge/radius ratio of the corresponding ions
8. The CFSE of a Cr^{3+} ion in an octahedral complex will be equal to :
- (A) $0.4 \Delta_0$
- (B) $0.8 \Delta_0$
- (C) $1.2 \Delta_0$
- (D) $1.6 \Delta_0$
9. Identify the name of the following reaction :
- The diagram shows a phenol ring with an R group at the para position. It reacts with CHCl_3 and a base to form a salicylaldehyde derivative (2-hydroxy-1-(R)benzaldehyde).
- (A) Reimer-Tiemann Reaction
- (B) Mannich Reaction
- (C) Birch Reduction
- (D) Gatterman Reaction

SEAL

10. The product of the following reaction will be :
 $(\text{CH}_3)_3\text{C}-\text{Br} + \text{OH}^- \rightarrow (\text{CH}_3)_3\text{C}-\text{OH} + \text{Br}^-$

- (A) Racemic mixture
 (B) Retention product
 (C) Inversion product
 (D) None of the above

11. Identify the compound with the highest ring strain among the following :

- (A) Cyclobutane
 (B) Cyclopentane
 (C) Cyclopropane
 (D) Cyclohexane

12. Which one of the following is the most stable conformer of the given molecule ?

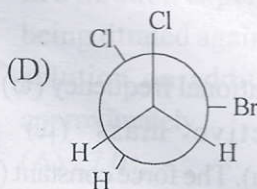
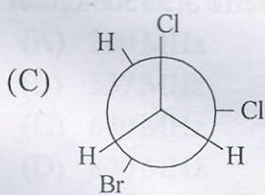
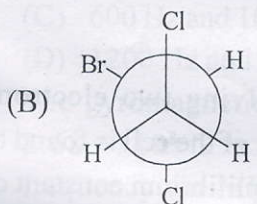
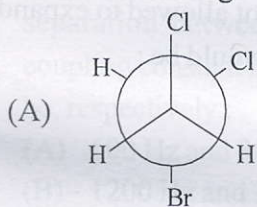

13. Identify the correct sequence with respect to inductive effects :

- (A) $\text{CF}_3 > \text{CH}_2\text{F} > \text{CHF}_2 > \text{CH}_3$
 (B) $\text{CF}_3 > \text{CHF}_2 > \text{CH}_2\text{F} > \text{CH}_3$
 (C) $\text{CH}_3 > \text{CH}_2\text{F} > \text{CHF}_2 > \text{CF}_3$
 (D) $\text{CH}_3 > \text{CHF}_2 > \text{CH}_2\text{F} > \text{CF}_3$

14. Which resonance contributor is incorrect representation of the following cation ?

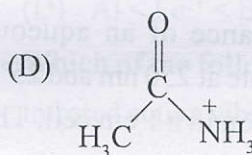
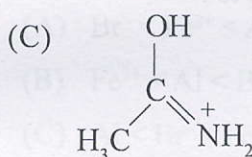
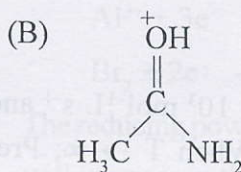
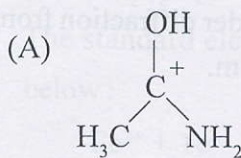
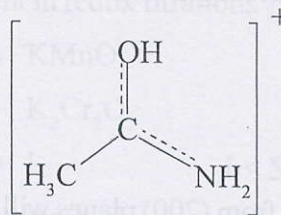

15. Determine the double bond stereochemistry (E or Z) for the following molecules :

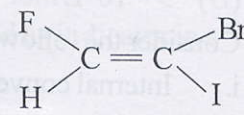
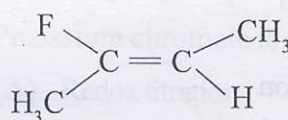

- (A) A : E and B : E
 (B) A : Z and B : E
 (C) A : E and B : Z
 (D) A : Z and B : Z

16. Which of the following is true about the compression factor of real gases ?
- $Z = 1$
 - $Z < 1$
 - $Z > 1$
 - Both $Z < 1$ and $Z > 1$
17. First order diffraction from (200) planes will occur at same angle as the _____ order diffraction from (100) planes for a cubic system.
- First
 - Second
 - Third
 - Fourth
18. The rate constant $k = 1.2 \times 10^3 \text{ mol}^{-1} \text{ L s}^{-1}$ and $E_a = 2.0 \times 10^2 \text{ kJ mol}^{-1}$. When $T \rightarrow \infty$; Pre-exponential factor A is equal to :
- $2.0 \times 10^2 \text{ kJ mol}^{-1}$
 - $1.2 \times 10^3 \text{ mol}^{-1} \text{ L s}^{-1}$
 - $1.2 \times 10^3 \text{ mol}^{-1} \text{ L}^{-1} \text{ s}^{-1}$
 - $2.4 \times 10^3 \text{ kJ mol}^{-1} \text{ s}^{-1}$
19. The percentage transmittance of an aqueous solution of disodium fumarate at 250 nm and 25°C is 50% for 0.0005 M solution in a 1 cm cell. The molar absorption coefficient, ϵ is :
- $1 \times 10^3 \text{ L mol}^{-1} \text{ cm}^{-1}$
 - $6.02 \times 10^2 \text{ L mol}^{-1} \text{ cm}^{-1}$
 - $1 \times 10^{-3} \text{ L mol}^{-1} \text{ cm}^{-1}$
 - $5 \times 10^4 \text{ L mol}^{-1} \text{ cm}^{-1}$
20. Consider the following :
- Internal conversion
 - Vibrational relaxation
 - Phosphorescence
 - Fluorescence
- Which of the above involves radiative processes ?
- i, ii and iii
 - ii and iii
 - ii, iii and iv
 - iii and iv
21. Consider the following statements with reference to thermodynamics :
- Heat (Q) is a state function
 - Work (W) is a state function
 - Internal energy (U) is a state function
- Which of the above statement(s) is/are correct ?
- 2 only
 - 3 only
 - 1 and 2 only
 - 1, 2 and 3
22. When one mole of an ideal gas is heated to double its initial temperature but not allowed to expand then the change in entropy would be :
- Zero
 - $(R - C_v) \ln 2$
 - $C_v \ln 2$
 - $C_p \ln 2$
23. For a cell reaction involving two electrons, change, the standard e.m.f. of the cell is found to be 0.295 V at 25°C. The equilibrium constant for the reaction would be (Given $F = 96500 \text{ C mol}^{-1}$, $R = 8.314 \text{ JK}^{-1} \text{ mol}^{-1}$) :
- 10×10^2
 - 1.0×10^{10}
 - 2.0×10^{11}
 - 4.0×10^{12}
24. For HCl molecule, the vibrational frequency (ν) is 2989 cm^{-1} and effective mass (μ) is $0.1627 \times 10^{-23} \text{ g}$ (0.9799 amu). The force constant for this molecule is :
- $2.34 \times 10^3 \text{ dynes/cm}$
 - $5.16 \times 10^5 \text{ dynes/cm}$
 - $7.51 \times 10^7 \text{ dynes/cm}$
 - $9.32 \times 10^7 \text{ dynes/cm}$

25. The IR spectrum of an organic molecule shows, in addition to other peaks, a strong absorption band in the region $1730-1700\text{ cm}^{-1}$ and a broad absorption band in the region $3400-2400\text{ cm}^{-1}$. In your opinion, which of the following organic classes the said molecule belongs to ?
- (A) Hydrocarbons
(B) Alcohols
(C) Phenols
(D) Carboxylic acids
26. In a 200 MHz NMR spectrometer, a molecule shows two doublets separated by 400 Hz (2 ppm). The observed coupling constant is 10 Hz. The separation between these two signals and the coupling constant in a 600 MHz spectrometer will be, respectively :
- (A) 600 Hz and 30 Hz
(B) 1200 Hz and 30 Hz
(C) 600 Hz and 10 Hz
(D) 1200 Hz and 10 Hz
27. The gyromagnetic ratio (γ) for ^1H nucleus is $2.68 \times 10^8\text{ T}^{-1}\text{s}^{-1}$. The Larmor precession frequency (in MHz) of hydrogen nuclei in a magnetic field of 12.6 T is :
- (A) 300 MHz
(B) 537 MHz
(C) 640 MHz
(D) 800 MHz
28. In a titration experiment, 50.0 ml of 0.1N HCl is being titrated against 0.1N NaOH. The pH of the solution on addition of 49.9 ml of NaOH is approximately :
- (A) 7.0
(B) 6.0
(C) 4.0
(D) 3.0
29. Which of the following is not used as an oxidizing agent in redox titrations ?
- (A) KMnO_4
(B) $\text{K}_2\text{Cr}_2\text{O}_7$
(C) I_2
(D) $\text{Na}_2\text{S}_2\text{O}_3$
30. The standard electrode potential data are given below :
- $$\text{Fe}^{3+} + 1\text{e}^- \rightarrow \text{Fe}^{2+}; \text{}^\circ\text{E} = + 0.77\text{ V}$$
- $$\text{Al}^{3+} + 3\text{e}^- \rightarrow \text{Al}; \text{}^\circ\text{E} = - 1.66\text{ V}$$
- $$\text{Br}_2 + 2\text{e}^- \rightarrow 2\text{Br}^-; \text{}^\circ\text{E} = + 1.80\text{ V}$$
- The reducing power of Fe^{2+} , Al and Br^- in the series will increase in the order :
- (A) $\text{Br}^- < \text{Fe}^{2+} < \text{Al}$
(B) $\text{Fe}^{2+} < \text{Al} < \text{Br}^-$
(C) $\text{Al} < \text{Br}^- < \text{Fe}^{2+}$
(D) $\text{Al} < \text{Fe}^{2+} < \text{Br}^-$
31. Which of the following molecule does not show infrared active vibrations ?
- (A) N_2
(B) NO_2
(C) N_2O
(D) CH_4
32. Potassium chromate is used as indicator in :
- (A) Redox titration
(B) Complexation titration
(C) Neutralization titration
(D) Mohr titration

Part—B : Biology

1

33. The disaccharide sucrose is formed by a glycosidic bond between :
(A) Two glucose molecules
(B) Glucose and Fructose molecules
(C) Glucose and Galactose molecules
(D) Two fructose molecules
34. Adipocytes of vertebrate animals are meant for the storage of :
(A) Fat
(B) Proteins
(C) Carbohydrates
(D) Nucleotides
35. The precursor for Vitamin-A synthesis is :
(A) Anthocyanin
(B) Cholesterol
(C) β -carotene
(D) Glucose-6-phosphate
36. The organic non-protein part of an enzyme is called :
(A) Isoenzyme
(B) Apoenzyme
(C) Holoenzyme
(D) Prosthetic group
37. The large and small subunits of 70S ribosomes are :
(A) 40S and 30S respectively
(B) 30S and 40S respectively
(C) 50S and 30S respectively
(D) 30S and 50S respectively
38. Which of the following cell organelles lacks double membrane ?
(A) Chloroplast
(B) Mitochondria
(C) Nucleus
(D) Lysosome
39. Identify the gram negative bacteria among the following :
(A) *E. coli*
(B) *Haemophilus influenzae*
(C) *Streptococcus pneumoniae*
(D) *Pseudomonas aeruginosa*
40. The plant cells lack following organelle :
(A) Mitochondria
(B) Glyoxysomes
(C) Centrosomes
(D) Dictyosomes
41. The chain termination codons for protein synthesis are :
(A) UAA and UAG
(B) AUG and GUG
(C) GUA and GUU
(D) UGA and AUG
42. A tRNA carrying methionine during protein synthesis has the anti-codon :
(A) AUG
(B) UAC
(C) UAG
(D) UAA
43. During replication, the unwinding of double stranded DNA is facilitated by the enzyme :
(A) Topoisomerase
(B) Polynucleotide kinase
(C) DNA Ligase
(D) Helicase
44. The components of Lac operon are :
(A) Promotor and structural genes
(B) Operator and regulator genes
(C) Both (A) and (B)
(D) Neither (A) nor (B)
45. Which of the following represents restriction site for BamHI enzyme ?
(A) GGATCC
(B) AAGCTT
(C) GAATTC
(D) CCGG
46. Which of the following features is essential for a DNA element to act as vector in recombinant DNA technology ?
(A) Unique restriction site
(B) Selectable marker
(C) Origin of replication
(D) All the above



47. The amplification of gene of interest in a PCR is carried out by the enzyme :
- Reverse transcriptase
 - Taq Polymerase
 - Both (A) and (B)
 - Neither (A) nor (B)
48. Cos Sites of lambda phage are essential components of :
- PUC vector
 - Phagemid vector
 - Cosmid vector
 - Both (B) and (C)
49. The electrophoretic mobility of biomolecules is not influenced by :
- Stereochemistry of molecules
 - Molecular weight
 - Shape of molecule
 - Size of molecule
50. In SDS-PAGE, the migration of protein is primarily effected by :
- Charge of protein
 - Size of protein
 - Both (A) and (B)
 - Neither (A) nor (B)
51. Which of the following technique is used in DNA finger printing ?
- Southern blotting
 - Western blotting
 - Northern blotting
 - All the above
52. The cell organelle can be separated by which of the following techniques ?
- Gel electrophoresis
 - Western blotting
 - Differential centrifugation
 - All the above
53. The following body organ receives oxygenated blood only :
- Lungs
 - Gills
 - Liver
 - Spleen
54. In what form does the product of glycolysis enter TCA cycle ?
- Acetyl-CoA
 - Pyruvate
 - NADH
 - Glucose
55. Most of the fat digestion occurs in :
- Stomach
 - Small intestine
 - Duodenum
 - None of the above
56. The exchange of respiratory gases in lungs occurs mainly in :
- Bronchiole
 - Trachea
 - Bronchi
 - Alveoli
57. The physical barriers that form part of immune system are :
- Bones and mucosal membrane
 - Bones and skin
 - Skin and mucosal membrane
 - Fats and proteins
58. The antigen binding site on an antibody is called :
- Antitope
 - Epitope
 - Paratope
 - Endotope
59. Inflammation reaction is brought about by :
- Plasma cells
 - Mast cells
 - Adipose cells
 - None of the above
60. Which of the following molecule is not used for extra cellular signaling ?
- Autocrine
 - Endocrine
 - Paracrine
 - Cyclic AMP

OR
Part—C : Physics

33. Miller indices (hkl) of two planes have the same value. This implies that :
- (A) the planes are equispaced and perpendicular to each other
(B) the planes are equispaced and parallel to each other
(C) the planes are either parallel or perpendicular to each other but not equidistant
(D) the statement is wrong as no two planes can have the same Miller indices
34. Which of the following properties of reciprocal lattice are correct ?
- (i) The volume of a unit cell in the reciprocal lattice is inversely proportional to the volume of a unit cell of the direct lattice
(ii) Every reciprocal lattice vector is normal to a lattice plane in the direct lattice
(iii) Reciprocal lattice of an fcc lattice is a bcc lattice
- (A) (i) and (ii)
(B) (ii) and (iii)
(C) (i) and (iii)
(D) All are correct
35. What would be the greatest effect on the ideal gas law if there is a slight attractive force between the molecules ?
- (A) At low densities, the pressure would be less than that predicted by the ideal gas law
(B) At low densities, the pressure would be higher than that predicted by the ideal gas law
(C) At high densities, the pressure would be greater than that predicted by the ideal gas law
(D) There is no effect on pressure but temperature rises at low densities
36. In an ideal gas at temperature T , the average speed of the molecules :
- (A) increases as the square of the temperature
(B) increases linearly with the temperature
(C) increases as the square root of the temperature
(D) is independent of the temperature
37. The temperature at which the density of conduction electrons in intrinsic germanium equals that of intrinsic silicon at room temperature (300 K) is (take the gap energies of 1.1 eV for Si and 0.7 eV for Ge) :
- (A) 740 K
(B) 471 K
(C) 231 K
(D) 191 K
38. With the increase in temperature, the resistivity of
- (A) A semiconductor increases and resistivity of metal decreases
(B) A semiconductor decreases and resistivity of metal increases
(C) Increases for both metals and semiconductor
(D) Decreases for both metals and semiconductor
39. Hall voltage is :
- (A) Directly proportional to the current flow through the specimen, and the magnetic field strength, and is inversely proportional to the number density of charge carriers
(B) Directly proportional to the current flow through the specimen, and is inversely proportional to the number density of charge carriers and the magnetic field-strength
(C) Indirectly proportional to the current flow through the specimen, and is directly proportional to the number density of charge carriers and the magnetic field-strength
(D) Indirectly proportional to the current flow through the specimen, and the magnetic field strength, and is directly proportional to the number density of charge carriers

40. The figure shown below best describes :

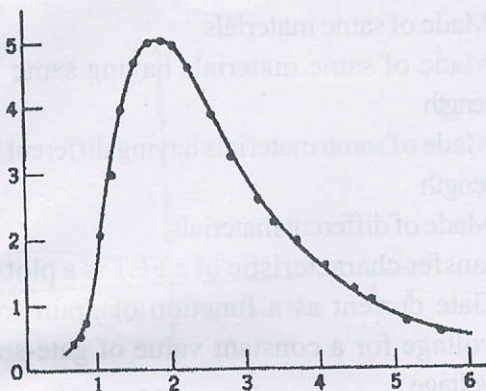

- (A) Reyleigh Jeans Law
 (B) Discharging of a capacitor
 (C) Black Body Spectrum
 (D) Wein's Law
41. An electron moves in the x direction with a speed of 4×10^6 m/s. We can measure its speed to a precision of 1%. With what precision can we simultaneously measure its position (i.e. its x coordinate) ?
 (A) 0.29 nm
 (B) 2.9 nm
 (C) 29 nm
 (D) 290 nm
42. A Helium atom, a neutron, a proton, and an electron all have the same non-relativistic kinetic energy. Which has the smallest de Broglie wavelength ?
 (A) Helium atom
 (B) Neutron
 (C) Proton
 (D) Electron
43. A particle of mass m is in the ground state of an infinite potential energy well of width L. The energy of the particle is 3 eV. How much energy must be added to the particle to cause it to jump to the first excited state ?
 (A) 3 eV
 (B) 6 eV
 (C) 9 eV
 (D) 12 eV

44. The quantized energy levels (E_n) in a Hydrogen atom are proportional to (where n is the principal quantum number) :
 (A) n
 (B) n^2
 (C) $\frac{1}{n}$
 (D) $\frac{1}{n^2}$
45. A grating with N slits produces maxima whose :
 (A) width is proportional to $1/N$ whose intensity is proportional to N^2
 (B) width is proportional to N and whose intensity is proportional to N^2
 (C) width is proportional to N^2 and whose intensity is proportional to N
 (D) width is proportional to N^2 and whose intensity is proportional to $1/N$
46. Bright and dark fringes are seen on a screen when light from a single source reaches two narrow slits a short distance apart. The number of fringes per unit length on the screen can be doubled if :
 (A) the distance between the slits is doubled and the wavelength is halved
 (B) the distance between the slits is doubled or the wavelength is halved
 (C) the distance between the slits is halved and the wavelength is doubled
 (D) the distance between the slits is halved or the wavelength is doubled
47. An unpolarized light wave is incident from air on a glass surface at the Brewster angle. The angle between the reflected and the refracted wave is :
 (A) 0°
 (B) 30°
 (C) 45°
 (D) 90°

33. 48. The minimum thickness of a soap film ($n = 1.3$) that results in constructive interference in reflected light if the film is illuminated with light whose wavelength in free space is 650 nm, is :
- (A) 125 nm
(B) 250 nm
(C) 211.25 nm
(D) 500 nm
34. 49. The magnetic vector potential $\vec{A} = B_0 \hat{x} \hat{j}$ gives rise to a uniform magnetic field equal to :
- (A) $B_0 \hat{k}$
(B) $B_0 \hat{i}$
(C) $B_0 (\hat{i} + \hat{k})$
(D) $B_0 (\hat{i} - \hat{k})$
35. 50. Using two of the Maxwell's equation (Faraday's and Ampere's law in vacuum), you can show that
36. $\nabla \times \nabla \times \vec{E} =$
- (A) $-\mu_0 \epsilon_0 \frac{\partial^2 \vec{H}}{\partial t^2}$
(B) $-\mu_0 \epsilon_0 \frac{\partial^2 \vec{E}}{\partial t^2}$
(C) $-\mu_0 \epsilon_0 \frac{\partial \vec{H}}{\partial t}$
(D) $-\mu_0 \epsilon_0 \frac{\partial \vec{E}}{\partial t}$
37. 51. If a force \vec{F} is derivable from a potential function $V(r)$, where r is the distance from the origin of the coordinate system, it follows that :
- (A) $\nabla \cdot \vec{F} = V(r)$
(B) $\nabla \times V(r) = 0$
(C) $\nabla \times \vec{F} = 0$
(D) $\nabla V(r) = 0$
52. For an achromatic doublet, the two lenses must be :
- (A) Made of same materials
(B) Made of same materials having same focal length
(C) Made of same materials having different focal length
(D) Made of different materials
53. The transfer characteristic of a FET is a plot of :
- (A) Gate current as a function of drain-source voltage for a constant value of gate-source voltage
(B) Source current as a function of gate-drain voltage for a constant value of gate-source voltage
(C) Drain current as a function of gate-source voltage for a constant value of drain-source voltage
(D) Drain current as a function of drain-source voltage for a constant value of gate-source voltage
54. The transconductance of an n-channel enhancement MOSFET having threshold voltage $V_T = 5$ V and the operating point $V_{GS} = 9$ is (take $K = 3 \times 10^{-4} \text{ A/V}^2$) :
- (A) 24 mA/V
(B) 2.4 mA/V
(C) 0.24 mA/V
(D) 12 mA/V
55. The current gain for the first stage of an RC coupled amplifier is -40 and for the second stage is 10 . The total current gain of the two stages is :
- (A) -2000
(B) 90
(C) -1.25
(D) 10
56. If the sum of the distance of a point from two perpendicular lines in a plane is 1, then its locus is :
- (A) a parabola
(B) a circle
(C) a straight line
(D) a square

Which exponential function is represented by this graph?

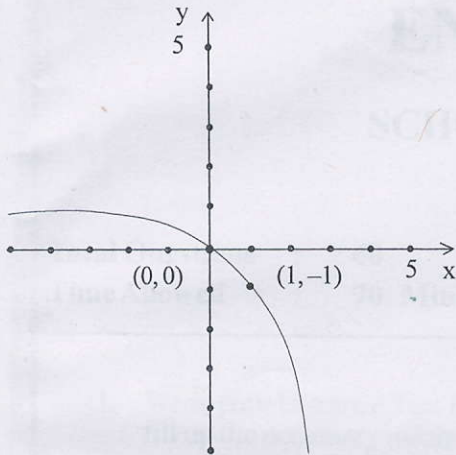

- (A) $f(x) = 1 + 2^x$
- (B) $f(x) = 1 - 2^x$
- (C) $f(x) = 1 + e^x$
- (D) $f(x) = 1 - e^x$

3. The Jacobian for the change-of-variables from cartesian coordinates to polar coordinates (i.e. the area element $dx dy$ in polar coordinates) is :

- (A) $r \sin \theta d\theta$
- (B) $r \cos \theta d\theta$
- (C) $r dr d\theta$
- (D) $r^2 \sin \theta dr d\theta$

59. What does a large standard deviation suggest?

- (A) The scores are not widely distributed and the median would be an unreliable measure of central tendency
- (B) All of the measures of central tendency would be reliable
- (C) Scores are widely distributed and that the mean may not be a reliable measure of central tendency
- (D) Scores are not widely distributed and the mean is a reliable measure of central tendency

60. The length of the angular momentum vectors that represent the orbital motion of an electron in a quantum state with $l = 2$, is :

- (A) $\sqrt{2} \frac{h}{2\pi}$
- (B) $\sqrt{3} \frac{h}{2\pi}$
- (C) $\sqrt{6} \frac{h}{2\pi}$
- (D) $\sqrt{12} \frac{h}{2\pi}$

SEAL

PART-(A) : CHEMISTRY

1. Consider the following statements :
1. Half life period of first order reaction is directly proportional to the initial concentration of reactants.
 2. A catalyst increases the rate of a reaction by lowering its activation energy.
 3. A zero order reaction takes finite time for completion while the first order reaction would get completed in infinite time.
- Which of the above statement(s) is/are correct ?
- (A) 1 & 2
 - (B) 2 & 3
 - (C) 1 & 3
 - (D) None of these
2. For a reaction, $A(g) + 2B(g) \rightarrow C(g) + D(g)$, $dx/dt = k[A][B]^2$. Initial concentration of A and B are respectively 0.6 M and 0.8 M. At a time when concentration of C is 0.2 M, rate of reaction relative to the initial value would be :
- (A) 1/6
 - (B) 1/48
 - (C) 1/4
 - (D) 1/24
3. On increasing temperature, the fraction of total gas molecules which has acquired most probable velocity will:
- (A) Increase
 - (B) Decrease
 - (C) Remain constant
 - (D) Can't say without knowing pressure
4. The percentage ionic character of a bond having bond length 1.275 Å and dipole moment 1.03 D is :
- (A) 10%
 - (B) 9.15%
 - (C) 16.83%
 - (D) 18.8%
5. For a cell reaction involving two electrons change, the standard e.m.f. of the cell is found to be 0.295 V at 25°C. The equilibrium constant of the reaction would be (Given $F=96500 \text{ C mol}^{-1}$; $R = 8.314 \text{ JK}^{-1}\text{mol}^{-1}$):
- (A) 10×10^2
 - (B) 1.0×10^{10}
 - (C) 2.0×10^{11}
 - (D) 4.0×10^{12}
6. Reaction of benzene with Cl_2 in presence of FeCl_3 forming chlorobenzene, is mechanistically an example of :
- (A) Addition reaction
 - (B) Substitution reaction
 - (C) Addition elimination reaction
 - (D) None of these
7. The redox reagents with an equivalent weight of 31.6 among the following can be :
- (A) Potassium Permanganate
 - (B) Oxalic acid
 - (C) Hydrogen peroxide
 - (D) Ferrous Sulphate hexahydrate
8. Which of the following is an acid base indicator ?
- (A) Diphenylamine
 - (B) Ferroin
 - (C) Potassium Chromate
 - (D) None of these
9. Among the ligands NH_3 , en, CN^- and CO, the correct order of their increasing field strength, is :
- (A) $\text{en} < \text{CN}^- < \text{NH}_3 < \text{CO}$
 - (B) $\text{CO} < \text{NH}_3 < \text{en} < \text{CN}^-$
 - (C) $\text{NH}_3 < \text{en} < \text{CN}^- < \text{CO}$
 - (D) $\text{CN}^- < \text{NH}_3 < \text{CO} < \text{en}$
10. Which of the following gives rise to Chemical shifts in NMR spectroscopy ?
- (A) Magnetic momentum
 - (B) Radio frequency
 - (C) Electron shielding
 - (D) Nuclear spin population in an energy state

11. What is the multiplicity expected in the hydrogen NMR spectrum for the hydrogen atoms marked by a "star" in the following compound?

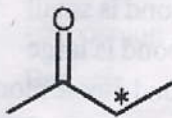

Butan-2-one

- (A) Singlet
(B) Triplet
(C) Quartet
(D) Heptet
12. Absorption of radiation in the UV range attributable to $n \rightarrow \pi^*$ electronic transitions is characteristic of which of the following types of compounds?
- (A) Aromatic hydrocarbons
(B) Unsaturated carbonyl compounds
(C) Non-conjugated polyenes
(D) Conjugated polyenes
13. Which of the following named reactions does not involve carbonyls?
- (A) Wittig reaction
(B) HVZ reaction
(C) Benzoin
(D) All of these
14. Which of the following is least reactive compound by the S_N1 mechanism?

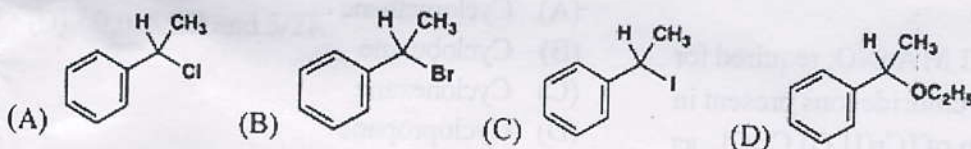

15. Which is most reactive in electrophilic substitution?

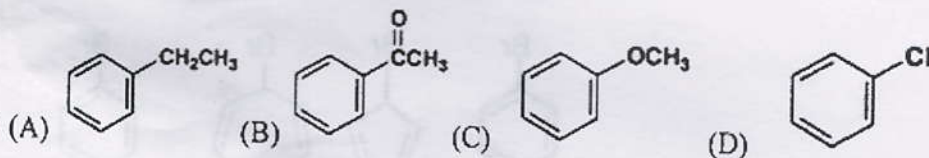

Quantitative analysis of an analyte based on measurement of weight of its precipitate is done in:

- (A) Titrimetry
(B) Coulometry
(C) Spectrophotometry
(D) Gravimetry

17. Phenolphthalein as a strong acid strong base titration indicator becomes colored in :
- (A) Acidic medium
(B) Alkaline medium
(C) Neutral medium
(D) Any of these
18. The correct shape of $[\text{TeF}_5]^-$ molecular ion on the basis of VSEPR theory can be :
- (A) Trigonal Bipyramidal
(B) Pentagonal planar
(C) See Saw Type
(D) Square Pyramidal
19. Identify the correct answer for medical application of metal compounds :
- | | |
|---------------|-----------------------|
| I | II |
| I. Gadolinium | a. Cancer |
| II. Gold | b. Manic Depression |
| III. Platinum | c. MRI Contrast agent |
| IV. Lithium | d. Arthritis |
- (A) I-b; II-a; III-c; IV-d
(B) I-c; II-b; III-d; IV-a
(C) I-d; II-c; III-a; IV-b
(D) I-c; II-d; III-a; IV-b
20. The volume (in mL) of 0.1 M AgNO_3 required for complex precipitation of chloride ions present in 30 mL of 0.01 M solution of $[\text{Cr}(\text{H}_2\text{O})_5\text{Cl}]\text{Cl}_2$, as silver chloride will be :
- (A) 3 mL
(B) 4 mL
(C) 5 mL
(D) 6 mL
21. Which of the following compounds can show a magnetic moment of 1.73 BM ?
- (A) $[\text{Cu}(\text{NH}_3)_4]^{2+}$
(B) $[\text{Ni}(\text{CN})_4]^{2-}$
(C) TiCl_4
(D) $[\text{CoCl}_6]^{4-}$
22. The band around 1600 cm^{-1} characteristic of a carbonyl group in the IR spectrum is very intense due to :
- (A) Force constant of CO bond is small
(B) Force constant of CO bond is large
(C) There is no change of bond dipole moment on CO stretching
(D) The dipole moment change due to CO bond stretching is large
23. Pure rotational spectrum is not shown by :
- (A) H_2O
(B) NO_2
(C) CO_2
(D) HCl
24. Which of the following statement(s) is/are true ?
- H_2O is an IR-active molecule
 - The spacing between any two successive spectral lines in a pure rotational spectrum of a diatomic molecule is $2B$
 - At absolute zero all translational, rotational and vibrational motions of a molecule cease
- (A) 1 & 2
(B) 2 & 3
(C) 1 & 3
(D) 1, 2 & 3
25. Identify the cycloalkane with the highest ring strain :
- (A) Cyclomethane
(B) Cyclobutane
(C) Cyclohexane
(D) Cyclopropane
26. The compound that can give precipitate on warming with aqueous AgNO_3 is :

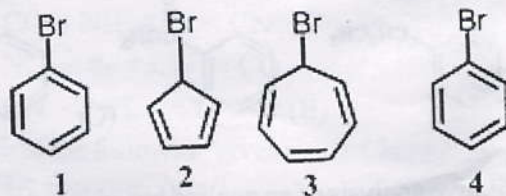

- (A) 1
(B) 2
(C) 3
(D) 4

27. What is the reaction intermediate in Reimer-Tiemann reaction ?
- Carbocation
 - Carboanion
 - Benzyne
 - Carbene
28. Consider the following statements with reference to thermodynamics :
- Heat (Q) is a state function
 - Work (W) is a state function
 - $Q+W$ is a state function
- Which of the above statement(s) is/are correct :
- 2 only
 - 3 only
 - 1 and 2 only
 - 1, 2 and 3
29. Q, W, ΔE and ΔH for a reversible isothermal expansion of one mole of an ideal monoatomic gas at 27°C from volume of 10 dm^3 to 20 dm^3 are respectively.
- $300R, -300R, 3/2R$ and $5/2R$
 - $+300R\ln 2, -300R\ln 2, 0$ and 0
 - $0, -300R\ln 2, 3/2R$ and $5/2R$
 - $0, 0, 3/2R$ and $5/2R$
30. pH of a solution can be determined by :
- Quinhydrone electrode
 - Calomel electrode
 - Glass electrode
 - Both (A) and (C)
31. Number of the components present in the system $\text{KCl-NaBr-H}_2\text{O}$ is :
- 3
 - 4
 - 2
 - 1
32. For a cubic crystal, the Miller indices of the plane for which interplanar spacing is $a/\sqrt{3}$ would be :
- 111
 - 211
 - 221
 - 222

PART-(B) : BIOLOGY

33. Polymerase chain reaction is used for generating large quantities of a specified DNA under the conditions of:
- (A) *In Vivo*
 - (B) *Ex-Vivo*
 - (C) *In Vitro*
 - (D) Transgenesis
34. The collection of DNA fragments from the total genome of a particular species by cloning is called as :
- (A) DNA library
 - (B) Cloning vector
 - (C) DNA fragmentation
 - (D) DNA denaturation
35. In SDS-PAGE, the molecules from a given mixture are separated based on the :
- (A) Charge
 - (B) Size
 - (C) Charge & Size
 - (D) Temperature
36. The blotting technique in which nucleic acids are directly blotted onto the filters without the electrophoresis is :
- (A) Southern blotting
 - (B) Northern blotting
 - (C) Western blotting
 - (D) Dot-blotting
37. The technique for generating amino acid coding changes in the DNA is known as :
- (A) Site Directed Mutagenesis
 - (B) Cloning
 - (C) Amplification
 - (D) None of these
38. In animal cell cultures, the adherent monolayers under the controlled conditions are detached by using :
- (A) Bacteria
 - (B) Viruses
 - (C) Plasmodium
 - (D) Trypsin
39. The storage form of high energy compound in invertebrates is usually :
- (A) Phosphoanhydride
 - (B) Phosphoarginine
 - (C) ATP
 - (D) GTP
40. The synthesis of 2,3 bisphosphoglycerate occurs in the tissues of :
- (A) Liver
 - (B) Kidney
 - (C) Erythrocytes
 - (D) Brain
41. The number of ATPs produced when a molecule of acetyl CoA is oxidized through citric acid cycle are :
- (A) 12
 - (B) 24
 - (C) 38
 - (D) 15
42. The carbon skelton during the synthesis of cysteine is provided by :
- (A) Serine
 - (B) Methionine
 - (C) Glutamate
 - (D) Alanine
43. Which of the following enzyme is associated with immunodeficiency disease ?
- (A) Xanthine Oxidase
 - (B) Adenosine Deaminase
 - (C) PRPP Synthetase
 - (D) HGPRT
44. Who among following first studied the role of microbes in fermentation ?
- (A) Edward Jenner
 - (B) Jakob Henle
 - (C) Louis Pasteur
 - (D) Ian Frazer

45. The molecules of MHC are primarily involved in :
- Antigen presentation
 - Macrophage differentiation
 - Hormone secretion
 - Toxin secretion
46. Which of the following disease is not an autoimmune disease ?
- Rheumatoid Arthritis
 - Myasthenia Gravis
 - Insulin Dependent Diabetes with auto-reactive T-cells & antibodies
 - HIV
47. Which of the following is not an aldose sugar ?
- Glucose
 - Galactose
 - Mannose
 - Fructose
48. The number of mg of KOH required to hydrolyze 1 g of fat or oil is called as :
- Iodine number
 - Saponification number
 - Reichert-Meissl number
 - Acid number
49. During denaturation of proteins, following bonding is not broken :
- Hydrogen bonding
 - Ionic bonding
 - Peptide bonding
 - Disulfide bonding
50. Following is the vitamin involved in the carboxylation of glutamic acid residues in blood clotting factors :
- Folic Acid
 - Vitamin B12
 - Ascorbic acid
 - Vitamin K
51. Protein folding chiefly involves
- Golgi complex
 - Mitochondria
 - Peroxisomes
 - Nucleus
52. The cancer cells generally have hyperactive :
- Mitochondria
 - Vacuoles
 - Endoplasmic reticulum
 - Cell membrane
53. The transport of glucose from the lumen to the intestinal mucosal cells is coupled with the diffusion of:
- Na^+
 - K^+
 - Cl^-
 - HCO_3^-
54. The superoxide ion is converted to H_2O_2 by the enzyme :
- Cytochrome Oxidase
 - Arginase
 - Superoxide Dismutase
 - Glucose Reductase
55. During the course of DNA replication in E.coli, the proof-reading function is carried out by :
- DNA Polymerase III
 - DNA Polymerase II
 - DNA Polymerase I
 - DNA helicase
56. The enzyme responsible for the synthesis of RNA primer in eukaryotes is known as
- DNA polymerase α
 - DNA polymerase β
 - DNA Polymerase γ
 - Topoisomerase

57. The peptidyltransferase involved in the formation of peptide bond during translation is chemically :
- t-RNA
 - r-RNA
 - mRNA
 - mi-RNA
58. A single tRNA has ability to recognize more than one codon by a process of :
- Degeneracy
 - Wobbling
 - Alternate splicing
 - Folding
59. The process of recombinant DNA technology involves all except :
- Restriction endonuclease
 - Vectors
 - Gene transfer & cloning
 - Wobbling
60. Which of the following cloning vectors has the highest capacity of taking foreign DNA ?
- Phage λ
 - Cosmid λ
 - Plasmid artificial chromosome
 - Yeast chromosome



OR
PART-(B) : PHYSICS

33. When two waves overlap we see (result is) :
- (A) individual waves
 - (B) resultant wave
 - (C) both individual as well as resultant waves
 - (D) neither individual nor resultant waves
34. A zone plate is a device used to focus light using :
- (A) refraction
 - (B) reflection
 - (C) diffraction
 - (D) transmission
35. The direction of propagation of electromagnetic wave is given by :
- (A) $\vec{E} \cdot \vec{B}$
 - (B) \vec{E}
 - (C) \vec{B}
 - (D) $\vec{E} \times \vec{B}$
36. When a charged particle moves in a uniform electric field, the force acting on it is :
- (A) perpendicular to the direction of field
 - (B) along the direction of the field
 - (C) opposite to the direction of the field
 - (D) either in the direction of field or opposite to it
37. The Poisson's equation is satisfied by :
- (A) electric vector potential
 - (B) magnetic vector potential
 - (C) both electric & magnetic potential
 - (D) neither electric nor magnetic potential
38. The electric field intensity \vec{E} due to an infinite uniformly charged plane sheet at a point distant r from the sheet is related as :
- (A) $\vec{E} \propto r$
 - (B) $\vec{E} \propto r^{-1}$
 - (C) $\vec{E} \propto r^2$
 - (D) \vec{E} is independent of r
39. By faithful amplification of an input signal using transistor as an amplifier we mean :
- (A) change in the magnitude as well as shape of the input signal
 - (B) change in the magnitude but not in the shape of the input signal
 - (C) neither there is change in the magnitude nor in the shape of the input signal
 - (D) either there is change in the magnitude or there is change in the shape of the input signal
40. The output characteristics of bipolar junction transistor (BJT) and field effect transistor (FET) are respectively controlled by :
- (A) input voltage and input current
 - (B) input current and input voltage
 - (C) either input current or input voltage
 - (D) neither input current nor input voltage
41. The index of refraction of a transparent medium differs for different wavelengths of the light used and the defects arising from such a variation of the refractive index are termed as :
- (A) monochromatic aberration
 - (B) chromatic aberration
 - (C) neither monochromatic nor chromatic aberration
 - (D) none of them
42. An object is placed on the principal axis of a concave mirror of focal length 10 cm at a distance of 8.0 cm from the pole. The position and nature of the image is:
- (A) at 40 cm & virtual
 - (B) at 40 cm & real
 - (C) at -40 cm & virtual
 - (D) at -40 cm & real

43. The data points (0,0), (1,1), (2,8) & (3,27) represent the :
- linear function
 - non linear function
 - a function of linear combinations of linear and non linear terms
 - all the above
44. The ordinary differential equation contains :
- one or several derivatives of an unknown function $y(x)$
 - only one derivative of an unknown function $y(x)$
 - one or several derivatives of unknown functions of two or more variables say $y(x)$, $z(x)$ etc
 - only one derivative of an unknown function of two or more variables say $y(x)$, $z(x)$ etc
45. Among the following which is an object oriented language ?
- PASCAL
 - FORTRAN
 - C++
 - COBOL
46. The characteristics of data set is best known by its :
- individual data points
 - mean value
 - mean value & standard deviation
 - all the above
47. Particles that most effects material properties are :
- Neutrons
 - Protons
 - Electrons
 - Valence electrons
48. In the crystal analysis x-rays are the most useful than other radiations of the electromagnetic spectrum because :
- x-rays contain high energy to penetrate the crystal deeply
 - x-rays contain high intensity to penetrate the crystal deeply
 - the wavelength of x-rays are of the order of inter-atomic spacing of solids
 - the wavelength of x-rays are not of the order of inter-atomic spacing of solids
49. Heat capacity of most materials is approximately equal to :
- R
 - 2R
 - 3R
 - R/2
50. The relationship between mean free path λ and the number of molecules per unit volume n is :
- $\lambda \propto n$
 - $\lambda \propto 1/n$
 - $\lambda \propto \sqrt{n}$
 - $\lambda \propto n^2$
51. The true statement about the drift velocity and that of random speed of free electrons in metals is :
- drift velocity is much smaller than random speed
 - drift velocity is much larger than random speed
 - drift velocity is equal to random speed
 - none of the them
52. The interaction of free electron in a periodic potential modifies the expressions of :
- Energy but not of wave function
 - Wave function but not of energy
 - Wave function as well as energy
 - Neither energy nor wave function
53. If an n-type and p-type semiconductors are joined together then some of the :
- free electrons will diffuse from the n region into the p-region
 - free electrons will diffuse from the p-region into the n-region
 - no free electrons at all will diffuse each other
 - none of them
54. The base of a transistor is :
- heavily doped
 - lightly doped
 - moderately doped
 - all the above

55. If the Compton wavelength of an electron is λ_c . The maximum wavelength change in the Compton effect is:
- (A) 0
 - (B) λ_c
 - (C) $2\lambda_c$
 - (D) none of them
56. The de Broglie hypothesis is associated with:
- (A) wave nature of electrons only
 - (B) wave nature of alpha particles only
 - (C) wave nature of photons only
 - (D) wave nature of all material particles
57. The normalized wave function of a particle trapped in a 1-dimensional box of length L is:
- (A) $\sqrt{2/L} \sin n\pi x / L$
 - (B) $2/L \sin n\pi x / L$
 - (C) $\sqrt{2/L} \sin n\pi L / x$
 - (D) $2/L \sin n\pi L / x$
58. The regions of forbidden energies (discrete energy spectrum) arise when the:
- (A) particle is free
 - (B) particle is trapped
 - (C) either free or trapped
 - (D) neither free nor trapped
59. The penetration of light into the region of geometrical shadow is called:
- (A) polarization
 - (B) interference
 - (C) diffraction
 - (D) refraction
60. If a small source of light never casts a sharp shadow of an opaque object, it indicates that:
- (A) Light always travels in a straight path
 - (B) Light never travels in a straight path
 - (C) Light travels both in straight as well as non straight path
 - (D) All the above

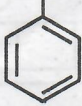
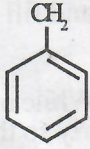
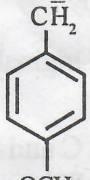
PART-(A) : CHEMISTRY

1. Identify the molecule with Non-zero dipole moment :
- (A) BF_3
 (B) CO_2
 (C) N_2O
 (D) 1,2-dichloroethane (trans isomer)
2. The most stable carbanion among the following is :
- (A) 
- (B) 
- (C) 
- (D) 
3. Elements X and Y are both univalent, X is electropositive while Y is strongly electronegative, the compound formed between them would likely be :
- (A) $\text{X}-\text{Y}$
 (B) X^+Y^-
 (C) X^-Y^+
 (D) $\text{X} \rightarrow \text{Y}$
4. The coordination number of an atom in primitive cubic, body centered cubic and face centered cubic unit cells respectively is :
- (A) 1,2,8
 (B) 6,8,12
 (C) 3,4,6
 (D) 2,4,16
5. Chlorobenzene reacts with Mg in dry ether to give a compound A which further reacts with ethanol to yield :
- (A) Phenol
 (B) Benzene
 (C) Ethyl Benzene
 (D) Phenyl Ether
6. The electronic configuration $1s^2 2s^2 2p^6 3s^2 3p^6 3d^{10}$ represents :
- (A) Ni
 (B) Ni^{2+}
 (C) Cu^{2+}
 (D) Cu^+
7. For the isothermal reversible expansion of an ideal gas, select the incorrect statement :
- (A) Work done = $-nRT \ln \frac{V_2}{V_1}$
 (B) $\Delta S = nR \ln \frac{V_2}{V_1}$
 (C) $\Delta U = 0$
 (D) $\Delta H = 0$
8. Which of the following is used to convert benzenediazonium Chloride into benzene ?
- (A) CH_3OH
 (B) $\text{Br}_2/\text{H}_2\text{O}$
 (C) H_3PO_2
 (D) LiAlH_4
9. The exact path of an electron in 2p orbital cannot be precisely determined, the statement is based upon :
- (A) Hund's rule
 (B) de Broglie hypothesis
 (C) Aufbau Principle
 (D) Hisenberg's Principle

10. Heat supplied to a Carnot engine is 2000 kJ. The maximum work that the engine can do if it works between 27 °C and 127 °C will be :
 (A) 1574 kJ
 (B) 1574 J
 (C) 500 J
 (D) 500 Kj
11. α -Tocopherol is found in :
 (A) Vegetable Oil
 (B) Lemon
 (C) Peanuts
 (D) Tomatoes
12. Which of the following molecules will not display an infrared spectrum ?
 (A) CO₂
 (B) N₂
 (C) Benzene
 (D) CHCl₃
13. The rate law for photochemical decomposition of HI

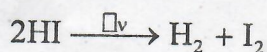

$$\text{Is Rate} = -\frac{d[\text{HI}]}{dt} = k_1 I_a \left(1 + \frac{1}{1 + \frac{k_4[\text{I}_2]}{k_2[\text{HI}]}} \right),$$

where I_a is the intensity of absorbed radiation. Which among the following expresses rate law at very high [HI] ?

- (A) $\text{Rate} = -\frac{d[\text{HI}]}{dt} = 2k_1 I_a$
 (B) $\text{Rate} = -\frac{d[\text{HI}]}{dt} = k_1 I_a$
 (C) $\text{Rate} = -\frac{d[\text{HI}]}{dt} = \frac{3k_1 I_a}{2}$
 (D) $\text{Rate} = -\frac{d[\text{HI}]}{dt} = k_1 k_2 I_a [\text{HI}]$

14. From the following values of dissociation Constant of four acids, which represents Strongest acid ?
 (A) 2×10^{-2}
 (B) 0.02×10^{-1}
 (C) 3×10^{-4}
 (D) 2×10^{-4}
15. The vibrational degree of freedom in an ammonia molecule is :
 (A) 7.
 (B) 6.
 (C) 10.
 (D) 5.
16. The number of components in systems KCl–NaCl–H₂O and KCl–NaBr–H₂O respectively are :
 (A) 3 and 3 respectively
 (B) 4 and 4 respectively
 (C) 3 and 4 respectively
 (D) 4 and 3 respectively
17. The reaction of toluene with Cl₂ in presence of FeCl₃ gives predominantly :
 (A) m-Chlorobenzene
 (B) Benzoyl Chloride
 (C) Benzyl Chloride
 (D) o and p-Chlorotoluene
18. Match the redox reagents with their equivalent weights :
 1. Potassium Permanganate (acidic medium) i. 31.6
 2. Oxalic acid (COOH)₂ ii. 52.66
 3. Hydrogen peroxide (H₂O₂) iii. 152
 4. Ferrous Sulphate (FeSO₄) iv. 17
 v. 45
 (A) 1-i, 2-v, 3-iv, 4-ii
 (B) 1-ii, 2-v, 3-iv, 4-iii
 (C) 1-i, 2-v, 3-iv, 4-iii
 (D) 1-v, 2-iii, 3-iv, 4-ii

19. For an electrochemical cell represented by :
 $\text{Zn} | \text{Zn}_{\text{aq}}^{2+} || \text{Cu}_{\text{aq}}^{2+} | \text{Cu}$. Given that, $\text{Cu}_{\text{aq}}^{2+} + 2e^- \rightarrow \text{Cu}$,
 $E^\circ = +0.35 \text{ V}$ and $\text{Zn}_{\text{aq}}^{2+} + 2e^- \rightarrow \text{Zn}$, $E^\circ = -0.763 \text{ V}$.
 The net emf of the cell will be :
 (A) 0.413 V
 (B) -0.413 V
 (C) 1.113 V
 (D) -1.113 V
20. Isopropyl Chloride undergoes hydrolysis by :
 (A) SN^1 Mechanism
 (B) SN^2 Mechanism
 (C) SN^1 Mechanism and SN^2 Mechanism
 (D) Neither SN^1 nor SN^2 Mechanism
21. What is incorrect in case of potassium permanganate titrations ?
 (A) These do not require a redox indicator
 (B) HCl cannot be used for the acidic medium required in this titration
 (C) For 20 mL of 0.1 N oxalic acid we need 15 mL of 0.1 N KMnO_4 for endpoint
 (D) The species inferring endpoint of this titration in acidic medium is colorless Mn^{2+} ion
22. The half-life of a first order reaction is 0.693 seconds. The time it takes for the reactant to reduce to 1 % of initial concentration will be :
 (A) 69.3 seconds
 (B) 6.93 seconds
 (C) 46.06 seconds
 (D) 4.606 seconds
23. Which of the following gives a ketone with Grignard's Reagent ?
 (A) Formaldehyde
 (B) Ethane nitrile
 (C) Ethyl alcohol
 (D) Methyl Iodide
24. From the given solubility product {Ksp} values, pick the most appropriate precipitating agent for gravimetric analysis of Ca^{2+} ions in solution ?
 $\text{CaSO}_4 = 2.4 \times 10^{-5}$; $\text{CaCO}_3 = 4.5 \times 10^{-9}$;
 $\text{Ca(OH)}_2 = 6.5 \times 10^{-6}$; $\text{CaCl}_2 = 1.57 \times 10^{-3}$.
 (A) Na_2SO_4
 (B) Na_2CO_3
 (C) NaOH
 (D) NaCl
25. Among the following strongest acid is :
 (A) CH_3COOH
 (B) $\text{CH}_2\text{ClCH}_2\text{COOH}$
 (C) CH_2ClCOOH
 (D) $\text{CH}_3-\text{CH}_2\text{COOH}$
26. The number of unpaired electrons in Ni(CO)_4 is :
 (A) Zero
 (B) One
 (C) Two
 (D) Three
27. Select the incorrect statement regarding the behaviour of gases :
 (A) Real gases behave ideally only under conditions of high temperature and low pressure
 (B) The compressibility factor for ideal gases is equal to one while for real gas it may be equal to, less than or more than one
 (C) At very high pressures the real gases are less compressible than an ideal gas
 (D) For real gas above Boyle temperature the compressibility factor decreases with increase of pressure

28. Which among the following is strongest acid ?



(C)

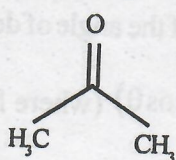

(D)

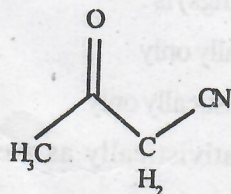

29. The effective atomic number of Cr in $[\text{Cr}(\text{NH}_3)_6]\text{Cl}_3$ is:

(A) 36

(B) 33

(C) 18

(D) 27

30. Select the most appropriate statement about a gas under high pressure expanding adiabatically into a region of low pressure :

(A) The gas gets cooled down if the temperature is less than the inversion temperature of the gas

(B) The gas does not experience any change in temperature, if the temperature is less than the inversion temperature of the gas

(C) The gas gets cooled down if the temperature is equal to the inversion temperature of the gas

(D) The gas gets cooled down no matter at what temperature the process takes place

31. The mechanism for the reaction :

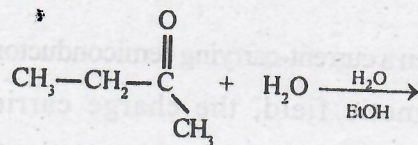

(A) SN^1

(B) SN^2

(C) SE^2

(D) SE^1

32. Which of the following bonds has the most ionic character ?

(A) Cs-Cl

(B) Al-Cl

(C) C-Cl

(D) H-Cl

PART-(B) : PHYSICS

33. When a current-carrying semiconductor is kept in a magnetic field, the charge carriers of the semiconductor experience a force in a direction :
- (A) Perpendicular to both the magnetic field and the current
 (B) Parallel to both the magnetic field and the current
 (C) Perpendicular to the magnetic field and parallel to the current
 (D) Parallel to the magnetic field and perpendicular to the current
34. The continuous spectrum of the radiation within the volume of the black body at thermal equilibrium depends :
- (A) Only on temperature
 (B) Only on the kind of atoms in the body
 (C) Both on the temperature & the kind of atoms of the body
 (D) All the above
35. In photo-electric effect, the photo-current :
- (A) Increases with increase of frequency of incident photon
 (B) Decreases with increase of frequency of incident photon
 (C) Does not depend on frequency of photon but depends only on intensity of incident light
 (D) Depends both on intensity and frequency of the incident photon
36. In the Compton effect, the change of wavelength of the photon as a function of the angle of deflection is given as $\Delta\lambda = \frac{h}{mc}(1 - \cos\theta)$ (where h, m and c have their usual meanings) is :
- (A) Valid relativistically only
 (B) Valid non relativistically only
 (C) Valid both relativistically as well as non relativistically
 (D) All the above
37. Based on the two types of spin-orbit interactions. The right expression for two electron system is :
- (A) $J = j_1 - j_2$ & $J = L - S$
 (B) $J = j_1 + L$ & $J = j_2 + L$
 (C) $J = j_1 + j_2$ & $J = L + S$
 (D) $J = j_1 + S$ & $J = j_2 - S$
38. The condition for sustained interference of light is that :
- (A) Two interfering waves should be coherent
 (B) Two interfering waves should be same frequency
 (C) If interfering waves are polarized, they must be in the same state of polarization
 (D) All the above
39. A plane wavefront of light of wavelength 5×10^{-5} cm falls on an aperture and the diffraction pattern is observed in an eye piece at a distance of 1 meter from the aperture. The area of the half period zone is :
- (A) 0.0147 cm^2
 (B) 0.0157 cm^2
 (C) 0.0167 cm^2
 (D) 0.0187 cm^2

40. A diffraction grating is just able to resolve two lines of $\lambda = 5140.34 \text{ \AA}$ and $\lambda = 5140.85 \text{ \AA}$ in the first order. The number of lines on the grating is :
 (A) 10080
 (B) 11080
 (C) 12080
 (D) 13080
41. The indices of refraction of quartz for right handed and left handed circularly polarized light of wavelength 7620 \AA are 1.53914 and 1.53920 respectively. The rotation of the plane of polarization of light in degrees produced by a plate of 0.5 mm thickness is :
 (A) 5.1°
 (B) 6.1°
 (C) 7.1°
 (D) 8.1°
42. The energy stored by an inductor is given as $\frac{1}{2} Li^2$. It is stored in :
 (A) Current
 (B) Voltage
 (C) Magnetic field
 (D) Electric field
43. In a plane electromagnetic wave, the electric field oscillates at a frequency of $2 \times 10^{14} \text{ Hz}$ and amplitude 60 V/m . The amplitude of oscillating magnetic field is :
 (A) $20 \times 10^{-8} \text{ Wb/m}^2$
 (B) $30 \times 10^{-8} \text{ Wb/m}$
 (C) $40 \times 10^{-8} \text{ Wb/m}$
 (D) $50 \times 10^{-8} \text{ Wb/m}$
44. A monochromatic electromagnetic wave in vacuum is incident normally on a substance of refractive index 2, the ratio of the electric vector which is reflected to that of incident wave is :
 (A) $1/2$
 (B) $1/3$
 (C) $1/4$
 (D) $1/5$
45. The magnetic vector potential satisfies :
 (A) Laplace's equation
 (B) Poisson's equation
 (C) Both Laplace's and Poisson's equation
 (D) None of the above
46. The elements of JFET are the drain, the source and the gate. These correspond respectively to :
 (A) Collector, base and emitter of bipolar transistor
 (B) Collector, emitter and base of bipolar transistor
 (C) Emitter, collector and base of bipolar transistor
 (D) Emitter, base and collector of bipolar transistor
47. An ideal op-amplifier has :
 (A) Infinite voltage gain, infinite bandwidth, infinite input impedance and zero output resistance
 (B) Infinite voltage gain, infinite bandwidth, infinite input impedance and infinite output resistance
 (C) Infinite voltage gain, infinite bandwidth, zero input impedance and zero output resistance
 (D) Infinite voltage gain, infinite bandwidth, infinite input impedance and infinite output resistance
48. An optical system consisting of two thin lenses, one convex of focal length $+20 \text{ cm}$ and the other concave of focal length -10 cm , separated by a distance of 15 cm in air. Then :
 (A) The nodal points N_1 and N_2 coincide with principal points H_1 and H_2 respectively
 (B) The nodal points N_1 and N_2 coincide with principal points H_2 and H_1 respectively
 (C) The nodal points N_1 and N_2 does not coincide with principal points H_1 and H_2 respectively
 (D) None of them
49. The following is true about the chromatic aberration :
 (A) It does not occur with light of same wavelength
 (B) It results from the dispersive power of a material
 (C) It can be reduced by combining crown and flint glass
 (D) All the above is true

50. Imagine a graph for a particle in motion with constant acceleration. Then the true statement about the displacement and velocity for such a particle is :
- Displacement varies and velocity remains constant
 - Displacement remains constant and velocity varies
 - Displacement as well as velocity remains constant
 - Displacement as well as velocity varies
51. The graphical representation for the function $e^{-|x|}$ will be :
- Decreasing linearly on both sides of x-axis
 - Decreasing non linearly on both sides of x-axis
 - Increasing linearly on both sides of x-axis
 - Increasing non linearly on both sides of x-axis
52. The average of first 50 natural numbers is :
- 25
 - 26.5
 - 25.5
 - 25.7
53. The average of 25 measurements is 6.12 ± 2.09 , pretty close to our true value 6. The number after the \pm sign is known as the standard deviation. The percentage of all the measurements that fall in the range between $6.12 - 4.18$ and $6.12 + 4.18$:
- 95 %
 - 68 %
 - 99.7 %
 - 100 %
54. The packing fraction for an SC lattice as compared to that of FCC lattice is :
- Greater
 - Smaller
 - Equal
 - Not possible to say
55. The reciprocal lattice of simple cubic lattice is :
- Monoclinic
 - Triclinic
 - Cubic
 - Orthorhombic
56. In a gas at room temperature & atmospheric pressure, the magnitude of mean free path & the mean velocity is of the order of $2 * 10^{-5}$ cm & $4 * 10^4$ cm/second respectively. Then a molecule collides approximately :
- 10^6 times per second with other molecules
 - 10^7 times per second with other molecules
 - 10^8 times per second with other molecules
 - 10^9 times per second with other molecules
57. Elastic waves in crystals are made up of :
- Magnons
 - Polarons
 - Phonons
 - Photons
58. The conductivity of silver is $6.2 * 10^7/\Omega.m$ & the number of free electrons per unit volume is $5.8 * 10^{28}/m^3$. The relaxation time is :
- $2.8 * 10^{-14}$ s
 - $3.8 * 10^{-14}$ s
 - $4.8 * 10^{-14}$ s
 - $5.8 * 10^{-14}$ s
59. In a crystal where electron faces a periodic potential, the free wave function $\psi(x) = e^{ikx}$ of electron is modified as $\psi(x) = u(x)e^{ikx}$ where $u(x)$ is :
- A constant
 - Periodic function
 - Aperiodic function
 - All the above
60. An n-type semiconductor is due to & is :
- Pentavalent doping & is positively charged
 - Pentavalent doping & negatively charged
 - Pentavalent doping & electrically neutral
 - Trivalent doping & is positively charged

OR
PART-(B) : BIOLOGY

33. Which statement about the bacterial cell is UNTRUE ?
- (A) The main constituent of a Gram positive cell wall is peptidoglycan
 - (B) Bacterial cells have a large surface to volume ratio
 - (C) The cell wall may be a potential target for antibiotics
 - (D) A plasmid is contained within the bacterial chromosome
34. Which of the following reactions is required for proofreading during DNA replication by DNA Polymerase III ?
- (A) 3'-5' exonuclease activity
 - (B) 5'-3' exonuclease activity
 - (C) 3'-5' endonuclease activity
 - (D) 5'-3' endonuclease activity
35. Addition of a 5' 7-methyl guanosine cap to the primary RNA transcript during nuclear processing :
- (A) Facilitates the assembly of the spliceosome complex
 - (B) Inhibits translation of the RNA molecule into protein
 - (C) Protects the RNA against degradation by cellular exonucleases
 - (D) Identifies the transcript as a transfer RNA molecule
36. Which of the following is TRUE of the lac operon in *E. coli* ?
- (A) The operon is only switched on in the absence of lactose in the growth medium
 - (B) The lac operon messenger RNA is a polycistronic mRNA (it carries information for synthesis of several proteins)
 - (C) The enzyme β -galactosidase is only produced in large quantities when the lac repressor is bound to the operator
 - (D) The promoter is the binding site for the lac repressor
37. Which of the following types of protein could be coded by a tumour-suppressor gene ?
- (A) A protein that forms part of a growth factor signalling pathway
 - (B) A protein that controls progression through the cell cycle
 - (C) A protein that codes for a DNA repair enzyme
 - (D) A protein that helps prevent apoptosis
38. A vector is a molecule of DNA to which the fragment of DNA to be cloned is attached. A vector :
- (A) Must be capable of autonomous replication
 - (B) Must contain at least one specific nucleotide sequence recognized by a restriction endonuclease
 - (C) Must carry at least one gene that confers the ability to select the vector, such as an antibiotic resistant gene
 - (D) All of the above
39. *Hind* III is a restriction endonuclease commonly used to cut human DNA into pieces before inserting it into a plasmid. Which of the following is most likely to be the recognition sequence for this enzyme ?
- (A) AAGCTT
 - (B) AAGGAA
 - (C) AAGAGA
 - (D) AAGAAG
40. Polymerase Chain Reaction (PCR) technique has applications in :
- (A) Efficient comparison of normal cloned gene with an uncloned mutant form of the gene
 - (B) Detection of low-abundance nucleic acid sequences
 - (C) Prenatal diagnosis and carrier detection, for example, of cystic fibrosis
 - (D) All the above

41. Modification of histone proteins by acetylating will :
- Increase the transcription of target genes
 - Add methyl groups to the regulatory region of the target genes
 - Increase the condensation of chromatin
 - Increase the affinity of target genes
42. Which of the following statements about two-dimensional gel electrophoresis is completely correct ?
- SDS gel electrophoresis and isoelectric focusing both separate native proteins
 - SDS gel electrophoresis and isoelectric focusing both make use of the migration of proteins in an electric field
 - SDS gel electrophoresis and isoelectric focusing together make up the process of two-dimensional gel electrophoresis
 - Options (B) and (C) are both correct
43. Which of the following statements about the use of mass spectrometry in protein investigation is correct ?
- Mass spectrometry involves ionized molecules in the liquid phase
 - Mass spectrometry is used for analysing the three-dimensional shape of peptides
 - Ionic fragments are separated according to their mass-to-charge ratio in Mass spectrometry
 - Mass spectrometry involves the separation of ionic fragments on a gel
44. A physician would like to determine the global patterns of gene expression in two different types of tumor cells in order to develop the most appropriate form of chemotherapy for each patient. Which of the following techniques would be most appropriate for this purpose ?
- Southern blot
 - Northern blot
 - Microarray
 - ELISA
45. The rate of DNA synthesis in a culture of cells could be most accurately determined by measuring the incorporation of which of the following radiolabeled compounds ?
- Phosphate
 - Thymidine
 - Guanine
 - Adenine
46. On sensing a decreased blood volume, Hypothalamus responds by synthesizing which of the following hormones/molecules to increase blood volume ?
- Antidiuretic Hormone (ADH)
 - Atrial Natriuretic Peptide (ANP)
 - Nitric oxide
 - None of the above
47. Which one of the following statements concerning the binding of oxygen by hemoglobin is INCORRECT ?
- The Bohr effect results in a lower affinity for oxygen at higher pH values
 - Carbon dioxide increases the oxygen affinity of hemoglobin by binding to the C-terminal groups of the polypeptide chains
 - Oxyhemoglobin and deoxyhemoglobin have the same affinity for protons (H^+)
 - All of the above
48. Regarding the pentose phosphate pathway, which of the following statements is INCORRECT ?
- It is located in mitochondria
 - It generates reducing power as NADPH
 - Glucose-6-phosphate dehydrogenase catalyses the rate-limiting step
 - It produces five-carbon ribose sugars which can be used for nucleotide synthesis

49. Which enzyme is deficient in Niemann Pick's disease ?
- Tyrosinase
 - Sphingomyelinase
 - Glucocerebrosidase
 - Hexosamidase A
50. The idiotype of an antibody molecule is determined by the amino acid sequence of the :
- Variable region of the light chain
 - Constant region of the light chain
 - Variable regions of the heavy and light chains
 - Constant regions of the heavy and light chains
51. Which of the following statements is incorrect ?
- Synthesis of antibody in a primary response to a thymus-dependent antigen occurs predominantly in the blood
 - Antibodies in the secondary immune response generally have a higher affinity for antigen than antibodies formed in a primary response
 - Isotype switching occurs in the presence of antigen
 - Predominantly IgM antibody is produced in the primary response
52. Which of the following statements about CD8⁺ CTLs is CORRECT ?
- They must be activated before exerting their cytotoxic function
 - They lyse targets via perforin and granzymes
 - They cause target cell apoptosis
 - All of the above statements are correct
53. Which of the following bind to mast cells and cross-link, resulting in de-granulation and release of histamine ?
- IgA
 - IgE
 - IgG
 - IgM
54. Which among the following pairs of sugars are epimers of each other ?
- Glucose and Ribose
 - Glucose and Mannose
 - Glucose and Fructose
 - Glucose and Sucrose
55. Binding of a non-competitive reversible inhibitor, that binds an enzyme at a site other than the active site leads to :
- Increase in V_{max} with K_m remaining constant
 - Increase in K_m with V_{max} remaining constant
 - Decrease in V_{max} with K_m remaining constant
 - No change in V_{max} and K_m
56. Which of the following statements is correct ?
- The α -helix is stabilized primarily by ionic interactions between the side chains of amino acids
 - The α -helix is mostly composed of more than one polypeptide chain
 - β -sheets exist only in the antiparallel form
 - β -bends often contain proline
57. Vitamin K :
- Is a water-soluble vitamin
 - Is present in high concentration in skimmed milk
 - Plays an essential role in preventing thrombosis
 - Is synthesized by intestinal bacteria
58. A ligand receptor is identified in a plasma membrane of a living cell. The arrangement of that receptor within the membrane is best described as a/an :
- Lipid raft
 - Peripheral protein
 - Integral membrane protein
 - Lipid anchored protein
59. A vesicle within a cell must be transported to another region of the cell along the microtubules. Which of the following proteins may be involved in catalyzing this transport ?
- Spectrin
 - Dystrophin
 - Kinesin
 - Myosin
60. A cytosolic cellular structure with two subunits is observed to assemble and disassemble and to bind to mRNA and to associate, at times, with endoplasmic reticulum. The most likely identity of this structure is a :
- Golgi complex
 - Peroxisome
 - Lysosome
 - Ribosome